

MULTI MATERIAL POWDER DELIVERING SYSTEMS FOR SELECTIVE LASER MELTING

A. KINNEAR, I. YADROITSAVA & I. YADROITSEV
CENTRAL UNIVERSITY OF TECHNOLOGY, FREE STATE

Abstract

Selective Laser Melting (SLM) is a powder bed fusion process which is an additive manufacturing (AM) process, whereby a laser beam selectively fuses regions of a powder bed to form complex objects. Growth in the SLM field has revealed the need for parts containing multiple materials for applications in the medical, tool making, aerospace and other hi-tech industries. By applying multiple materials, regions with different mechanical properties, thermal conductivity zones or corrosion-resistant coatings can be achieved in a single manufacturing cycle utilizing the SLM process. With the SLM process physical bonds can be formed between different materials by creating an interlocking interface due to the rapid solidification of the molten materials. With the current SLM equipment, multi material objects are possible but only with material differences between the layers. New approaches are needed to develop a method that allows multi material parts not only in the Z axis, but also allow material differences on a single layer (X-Y axis). Approaches such as powder feeding through a capillary tube, auger feed system, electrostatic charge or masks have all been proposed as solutions to multi material deposition. Multi material objects produced in a single cycle with complex geometry and prescribed properties has the opportunity of further growing the AM market.

Keywords: Additive manufacturing, multi materials, selective laser melting

1. INTRODUCTION

Selective Laser Melting (SLM) is an additive manufacturing technology which allows directly built 3D objects in accordance with three-dimensional Computer Aided Design data. A thin layer of powder is deposited on to a build platform where a laser beam selectively melts the desired regions to form the required shape. The next layer of powder is deposited onto the previous layer and the process repeats until a 3D object is produced. The object is then immediately ready to be used as a prototype or final product. At the core of the SLM process is a laser beam scanning over the surface of a thin powder layer. As the laser beam melts material along a row of powder particles, it forms a molten pool. Each layer of the object is sequentially filled with elongated tracks of melted powder lines referred to as single tracks. Single tracks or the continuous formation of the molten pool is the most basic building block in the SLM process. The previously re-melted layer or the substrate forms the platform for the new layer of powder to be deposited and the process repeats.

The SLM process requires a thin powder layer (15-200 μm) to be deposited on the substrate before the powder is melted. The layer thickness as well as the powder bed surface quality affects the density of the object and the surface roughness directly. Currently there are three main powder recoating mechanism to form a powder layer on the build platform namely a roller, a stiff blade or a hopper. The current SLM powder delivery system limits the process to a single material per layer.

Multi-material layered manufacturing refers to a process of fabricating an object consisting of more than one material in a single manufacturing process (Fig. 1). By depositing multiple materials, regions with different mechanical properties, thermal conductivity zones or corrosion-resistant coatings can be achieved in a single manufacturing cycle utilizing the SLM process. The “ideal” multi material process will dispense multiple material powders on a single layer and between layers, producing a model with accurate geometry, acceptable density and surface quality with a reasonably short processing time. The SLM process is revealing new opportunities in the prototyping, manufacturing, aerospace, medical and tooling disciplines. The extent of SLM’s applications is still growing with the process even being used in the art and fashion industries. Growth in the SLM field has revealed the need for parts containing multiple materials.

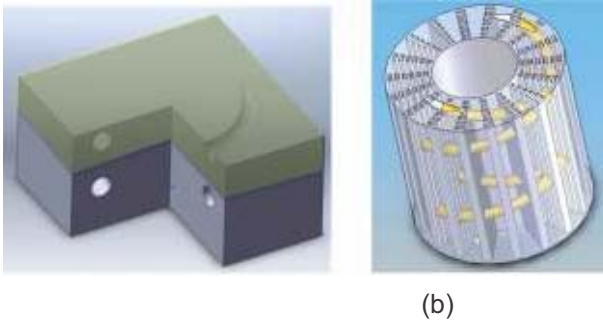

Figure 1: Multi material models: difference only between layers (a) and material differences between single layers (XY plane) and Z axis (b) (Yadroitsev et al., 2007, 2009).

Subramanian et al. (2014) describes a patent for multi material gas turbine blades. The blade consists of three different materials. Firstly a structural metal like titanium to provide mechanical strength and to maintain the shape of the air foil blade. Secondly a bond coat on the surface of the blade to protect the blade and thirdly a thermal barrier. The thermal barrier consists of a material with a higher heat capacity to increase the heat dissipated from the surface of the blade using 3D cooling channels.

The bio-medical sector utilizes the benefits of SLM to manufacture complex geometries and structures in high grade biocompatible materials. Using multiple materials on a single medical implant has the opportunity to greatly increase the quality of medical implants (Vaezi et al., 2013). Implants consisting of multiple biocompatible materials can be constructed to have different mechanical, chemical and physical properties in desired areas of the implant. Light weight porous titanium structures can be manufactured to provide suitable mechanical and bio-compatible properties while a copper coating at the implant interface prevents inflammation. Screw connections or weld joints can be avoided when considering the joint connections of different material in current implants.

Another sector that will majorly benefit from multi material processing is tool making for the plastic injection moulding industry. By using multiple materials in the mould design and integrating conformal cooling, the heat flow of a mould can be further improved. Materials such as copper that have higher thermal conductivity, in conjunction with conformal cooling produce an effective heat sink. Such a mould would contain for example a steel outer shell with a copper inside containing conformal cooling channels to efficiently conduct the heat away from the moulding cavity. This approach would lower the mould temperature considerably due to the increase heat rejection. Nickel/copper moulds with conformal channels led to productivity improvements of approximately 70% when compared to a similar mould made with conventional steel with drilled cooling channels (Dimla et al., 2005).

The multi material SLM process is the only technology that will have the capability of producing complex multi material objects in a single manufacturing cycle due to its layer by layer processing.

2. REVIEW OF MULTI MATERIAL SYSTEMS

2.1 Current conventional delivering systems in SLM

Commercially there are three main powder recoating mechanism to form a powder layer on the build platform namely a roller, a stiff blade or a hopper. Phenix systems utilizes a roller to deposit the powder from the powder delivery platform to the build platform. The powder layer thicknesses range from 10-50 μm (3D Systems, 2013).

EOS SLM machines deposits the powder with a recoating blade. Powder is shifted from the dispenser platform to the build platform by means of a stiff blade. The blade ensures an even layer of powder that the laser selectively melts. The build platform is lowered by a layer thickness and the dispenser platform is raised by one layer's volume (EOS GmbH, 2013).

Renishaw and SLM solutions use a hopper and blade to deposit the powder onto the powder bed with layer thicknesses of 20-100 μm (SLM Solutions GmbH, 2013). The hopper and blade method eliminates the need for a dispenser platform. According to the Renishaw website, “The AM250 features an external powder hopper with valve interlocks to allow additional material to be added whilst the process is running. It is possible to remove the hopper for cleaning or to exchange with a secondary hopper for materials change, using the universal lift. The powder overflow containers are outside the chamber and feature isolation valves so that unused materials can be sieved and reintroduced to the process via the hopper while the system is running” (Renishaw, 2012). This also allows the hopper to be removed while the process is running to allow a second material to be introduced on the build platform, but the difference in material will be between layers and not on the same layer.

In essence all three recoating systems are similar, each delivers an even powder layer over the build platform. The disadvantage of the current SLM recoating systems is that only one powder can be delivered per layer due to the pushing nature of the mechanisms.

2.2 Differences between layers

With modifications to the current commercial powder delivering systems, the SLM process has the ability to produce multi material models but the difference of material is between layers. Yadroitsev (2009) utilized a Phenix PM100 machine with a two-step manufacturing process to demonstrate the potential of producing multi material cooling systems using the SLM process. “Sandwich” samples containing stainless steel 316L, copper and Inconel 625 were successfully manufactured and proved the possibility of multi material parts. It furthermore proved that with the SLM process bonds between different materials could be formed that would usually not occur.

Liu et al. (2014) conducted experiments with multi material SLM samples containing 316L stainless steel and copper alloy further proving the possibility of multi material models and also investigating the bonds at the interface of the two materials. Utilizing a SLM250HL machine with a modified recoater, two different materials were dispensed independently on the substrate. This recoater allows different powders to be dispensed between layers. Tensile tests indicated that the stainless steel/copper specimens showed lower tensile stress than that of the stainless steel specimens but higher than that of copper specimens.

2.3 Systems for Functionally Graded Materials

Functionally Graded Materials (FGM) are the simplest form of multi material models and the easiest to manufacture. FGM refers to a multi material structure where by two or more materials have continuously varying volume fractions in a specific direction.

Varied material gradients are produced to suit a specific application and achieve higher levels of performance than models produced from a single material. For example, protective coatings and interfacial zones can be produced to reduce mechanical and thermally induced stresses caused by inadequate material properties. Functionally graded materials are ideal candidates for applications that experience severe thermal, mechanical and biological gradients. Due to the layer by layer nature of the SLM process, the composition of the material can be controlled within each layer and precise variations of the different materials can be deposited. By gradually changing the composition of material from a metal to ceramic or from metal to metal allows for varied thermal and mechanical regions (Aboudi et al., 1999) (Mahamood et al., 2012). Mumtaz et al. (2007) produced functionally graded Waspaloy and Zirconia samples. Waspaloy is a high temperature super nickel alloy used in the aerospace industry. Zirconia is a ceramic which typically is used to create thermal barrier coatings. Powder layers were deposited by means of a hopper that moved over the powder bed. This allowed for a variation in material composition in between layers (Z-axis).

Beal et al. (2004) manufactured functionally graded objects from H13 tool steel and copper powder on a custom build hopper powder feeding system. The experiment was conducted to prove the viability of functionally graded injection moulding tools. Variations of the powder mixture were deposited on a single layer (X-axis). The pre-mixture powders were placed in the compartments of the hopper according to the desirable composition design. The hopper moved over a platform spreading the powder mixtures into interlocking tracks (Fig. 2). This resulted in a material gradient on a single layer.

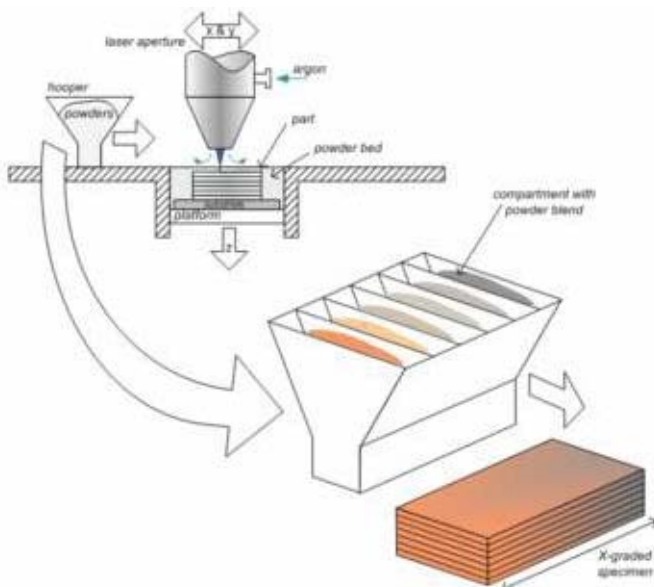

Figure 2: A schematic diagram of X-axis recoater. (Beal et al., 2004)

2.4 Multiple powder feeders for a single layer

Lappo et al. (2003) developed a system where a complete layer of the first material is dispensed with a roller. Selective removal of areas where the second material should be applied is done with electrostatic or vacuum methods. A nozzle is used to deposit the second material into the removed areas. A 2.5 mm diameter air pressurizes (0.1 psi) nozzle was utilized to induce flow of the fine powder (Fig. 3).

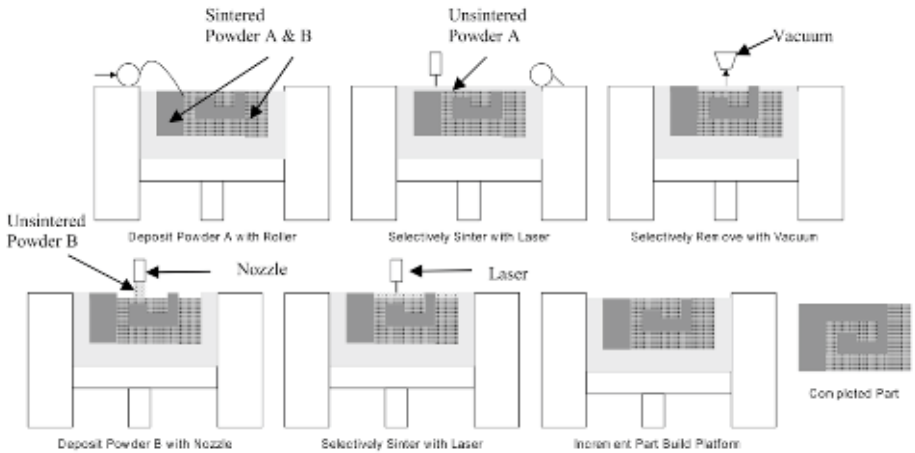

Figure 3: Multi material process schematic applied by Lappo et al. (2003).

Meiners et al. (2005) describe a patent for multi material model production where powder is deposited onto the build platform and selectively removed so as to introduce a second material (Fig. 4). A layer of the first powder is deposited on to the substrate. The areas of the first material are selectively melted and the unmelted material is removed (suction or electrostatic attraction). A nozzle system then deposits the second powder on to the desired areas and a laser beam melts the specific regions.

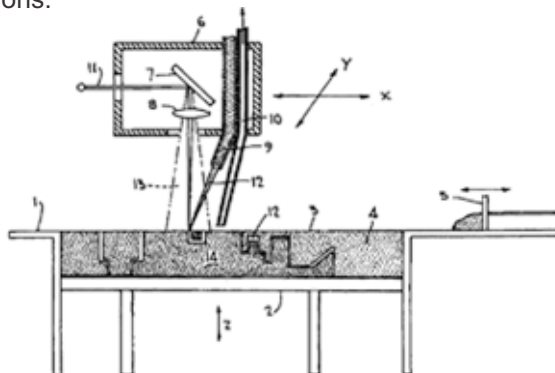

Figure 4: (Meiners et al., 2005) patent schematic.

Hovel et al. (2011) proposed a concept where the first material is deposited in powder form on to the substrate and is selectively melted by a laser or electron beam. There after the second material is applied in the form of a tape, sheet, foil, or three-dimensional pre-form where after it is selectively melted to produce the desired shape (Fig. 5).

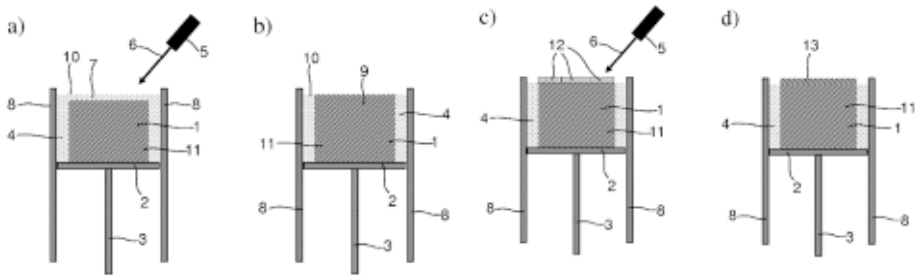

Figure 5: Hovel et al. (2011) multi material process.

Micro feeding of fine powder through a capillary tube with a vibration to induce flow is a common approach to dispensing powder on the build platform to create multi material models. Matsusaka et al. (1995) proved that continuous controlled discharge (0.2 mg/s) of fine powder (about 10 μm in size) through a vibrating capillary tube (0.4-1.6 mm diameter) is possible. It was concluded that a thin layer of micro vibrating powder particles forms on the inner wall of the tube and acts as lubrication to the powder flow. Li et al. (2002) used a piezoelectric transducer to produce an ultrasonic vibration (20 kHz) applied to the capillary tube (125 μm) to control the powder flow rate. Continuous discharge of the copper and stainless steel powders were achieved at a flow rate of approximately 10-5 g/s with a line width of 127 μm . In 2004 Li et al. patented the idea of vibration induced powder flow through a capillary tube to produce small scale models (Fig. 6).

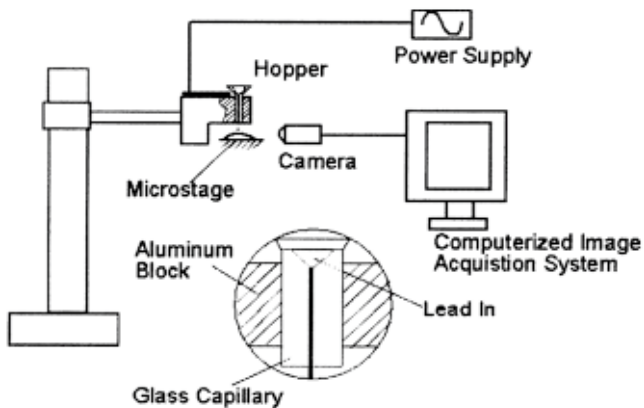

Figure 6: Micro-feeding experimental setup (Li et al., 2002)

Yang and Evans (2003) experimented with acoustic vibration to control the flow rate of dry powders in open capillaries. H13 tool steel powder (212 μm particle size) was dispensed through a glass capillary tube (450 μm inner diameter). The vibration was induced by a sub-woofer loudspeaker (40 Hz to 4 kHz frequency range). The study concluded that acoustic vibration is a valid approach for delivering powder to the build platform and that a difference in waveform, frequency and amplitude had an effect on the flow rate. A vibrating tube offers accurate powder dispensing (60–500 μm spatial resolution) but at small flow rates (≤ 1 mg/s). In 2007 they concluded that a vibrating capillary tube is one of the better approaches to solving the complex design problem of applying multiple materials on a single layer in the SLM process (Yang & Evans, 2007).

Al-Jamal et al. (2008) deposited multiple materials (copper and H13 tool steel) on a single layer to investigate the bond between the specific materials. Variation in the hardness over the interface area proved that there is a distinct region where the materials join and not a sharp dividing line. This was further proved by a tensile test on the specimen where the interface had a larger tensile stress than the weaker of the two materials. Powder was fed to the build platform via four hoppers. Each hopper contained its own material. Powder flow was induced with a 0.4 mm nozzle and a piezoelectric transducer to cause vibration.

Gu & Giuliani (2009) patented multiple powder feeders with a central dispensing hopper on a 3-axis system. The powder feeder comprises of a feed hopper and a feed screw. Each feed hopper is filled with a different powder and is feed to the build platform via the dispensing hopper (Fig. 7).

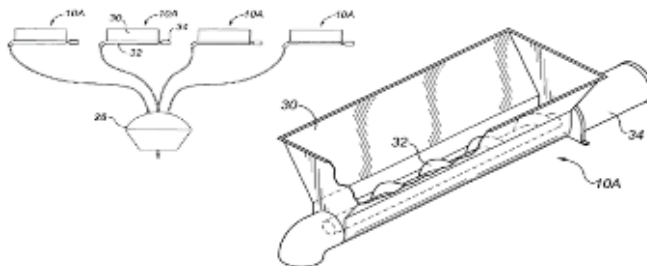

Figure 7: Schema of multiple powder feeders (Gu & Giuliani, 2009).

The problem with multi material powder dispensing is to create a smooth, consistent powder thickness layer. Dispensing powder through a nozzle or capillary tube especially has this problem due to the extruding nature of single tracks of powder onto the build platform. As single tracks are positioned next to each other they cause a ridge between the two single tracks. These ridges lead to an uneven powder bed surface which has a direct negative effect on the laser single track formation.

Inadequate laser single track formation leads to rough surface finishes on the models as well as less dense 3D SLM objects (Ott & Zaeh, 2010).

Van der Eijk et al. (2004) suggested a process using the laws of electrostatic charge and fields to generate the layers. A photoreceptor is charged to a specified charge density using a scorotron. An electrostatic image of the part slice is created on the photoreceptor by light exposure, using a computer controlled LED printer head. The light exposure causes the photoreceptor to retain the electrostatic charge only for the image of the slice. After that the photoreceptor plate is aligned horizontally over the powder reservoir where the electrostatic force causes the powder to be attracted to the plate in the exact image of the part slice. The layer of powder is then deposited on the build platform by discharging the electrostatic charge of the photoreceptor (Fig. 8).

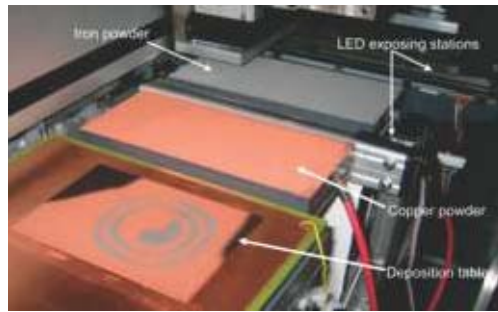

Figure 8: Electrostatic powder dispenser (van der Eijk et al., 2004)

Phenix Systems (2012) patented a concept of producing multi material models where by a mask is used to deposit different powders onto selected regions of the build platform (Fig. 9). A mask refers to a film that is place over the build platform, which exhibits the negative form of the desired geometry. The mask is formed by binding material (resin or polymer) selectively to a fine mesh utilizing a laser. A layer of powder is deposited over the mask so that the powder flows through the opening of the mask and onto the build platform. Thus depositing powder of the first material into the desired regions. The powder is then selectively melted by a laser beam. The left over powder of the first material on the mask is removed and the mesh is spoiled so to produce a clean sheet of mesh. The binding material is then formed on the mesh to produce a mask for the second material, and the process repeats with the second material. Consecutive layers of the process form a 3D model.

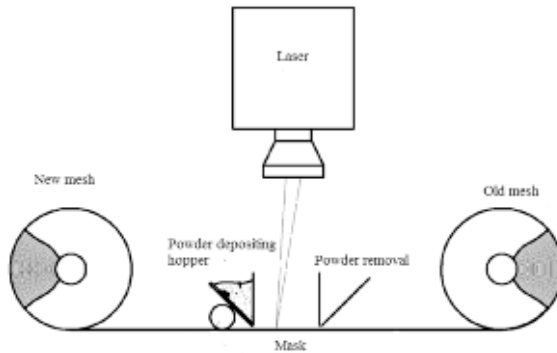

Figure 9: Phenix Systems (2012) multi material process.

3. CONCLUSION AND FURTHER RESEARCH

Modern commercial SLM machines can produce complex SLM parts from one material on a specific layer. Currently there are two experimental approaches to create multi material objects utilizing SLM.

- 1) Firstly, powder is deposited on the building platform in the appropriate regions and the material is selectively melted by a laser. Non-sintered powder is removed by suction or electrostatic methods. The second powder is delivered and selectively melted. Additional modifications to this approach use a tape, sheet, foil, or three-dimensional pre-form to introduce the second material.
- 2) Different powders are deposited on the building platform i) by hoppers with different cells for each powder, ii) by special nozzles (capillaries) with acoustic vibration to facilitate the application of the powder, iii) by electrostatic methods, iv) or by using specially shaped sieving masks to deposit different materials. The powder layer is then scanned by a laser beam, thus creating a 3D object.

Literature indicates a few prototypes of multi material systems, but all of them are conceptual. Original solutions for multi material delivering systems are a vital task for future progress in SLM.

4. ACKNOWLEDGEMENT

The active support and funding by the South African Department of Science and Technology and the National Research Foundation for the Collaborative Program in Additive Manufacturing and South African Research Chairs Initiative (SARChI) are gratefully acknowledged.

5. REFERENCES

05. Device and method for the preparation of building components from a combination of materials, Patent US6861613B1.

3D Systems, 2013. Phenix PX Boucher. Available at: <http://www.3dsystems.com> [Accessed January 7, 2015].

Aboudi, J. et al., 1999. Higher-order theory for functionally graded materials. *Composites Part B: Engineering*, 30, pp.777–832.

Al-Jamal, O.M., Hinduja, S. & Li, L., 2008. Characteristics of the bond in Cu-H13 tool steel parts fabricated using SLM. *CIRP Annals - Manufacturing Technology*, 57, pp.239–242.

Beal, V.E. et al., 2004. Fabrication of x-graded H13 and Cu powder mix using high power pulsed Nd: YAG laser. Conference Proceeding of Solid Freeform Fabrication Symposium, August 2-4, 2004, Austin, TX, USA, University of Texas at Austin, pp.187–197.

Dimla, D.E., Camilotto, M. & Miani, F., 2005. Design and optimisation of conformal cooling channels in injection moulding tools. *Journal of Materials Processing Technology*, 164-165, pp.1294–1300.

EOS GmbH, 2013. EOSINT M280 Brochure. Available at: <http://ip-saas-eos-cms.s3.amazonaws.com> [Accessed January 7, 2015].

Hovel, S. et al., 2011. Method of applying multiple materials with selective laser melting on a 3d article, US 20110106290A1.

Gu, P. & Giuliani, V., 2009. Multisource and multi material freeform fabrication. Patent US007572403B2.

Lappo, K. et al., 2003. Discrete multiple material selective laser sintering (M2SLS): Nozzle design of powder design. Conference Proceeding of Solid Freeform Fabrication Symposium, August 4-6, 2003, Austin, Texas, University of Texas at Austin, pp.93–108.

Li, X., Choi, H. & Yang, Y., 2002. Micro rapid prototyping system for micro components. *Thin Solid Films*, 420-421, pp.515–523.

Li, X., Yang, Y. & Choi, H., 2004. Apparatus and method of dispensing small-scale powders. Patent US 20040012124A1.

Liu, Z.H. et al., 2014. Interfacial characterization of SLM parts in multi-material processing: Metallurgical diffusion between 316L stainless steel and C18400 copper alloy. *Materials Characterization*, 94, pp.116–125.

Mahamood, R.M. et al., 2012. Functionally Graded Material: Conference Proceeding of World Congress on Engineering, London, U.K., 4-6 July, 2012, preface.

Matsusaka, S., Urakawa, M. & Masuda, H., 1995. Micro-feeding of fine powders using a capillary tube with ultrasonic vibration. *Advanced Powder Technology*, 6(4), pp.283–293.

Meiners, W. et al., 2005. Device and method for the preparation of building components from a combination of materials, Patent US6861613B1.

Mumtaz, K.A. & Hopkinson, N., 2007. Laser melting functionally graded composition of Waspaloy and Zirconia powders. *Journal of Materials Science*, 42(18), pp.7647–7656.

Ott, M. & Zaeh, M.F., 2010. Multi-Material Processing in Additive Manufacturing. Conference Proceeding of Solid Freeform Fabrication Symposium, August 9-11, 2010, Texas, Austin, USA, University of Texas at Austin, pp.195–203.

Phenix systems., 2012. Method for creating an object, by means of laser treatment, from at least two different powder materials, and corresponding facility, Patent US20120228807A1.

Renishaw, 2012. Brochure: The power of Additive Manufacturing. Available at: <http://resources.renishaw.com> [Accessed January 9, 2015].

SLM Solutions GmbH, 2013. SLM 500 HL Brochure. Available at: <http://stage.slm-solutions.com> [Accessed January 6, 2015].

Subramanian, R. et al., 2014. Additive manufacture of turbine component with multiple materials. Patent US 20140099476A1.

Vaezi, M. et al., 2013. Multiple material additive manufacturing. *Virtual and Physical Prototyping*, 8(1), pp.19–50.

Van der Eijk, C. et al., 2004. Metal printing process - development of a new Rapid Prototyping process for metal parts. Conference Proceeding World PM Conference, Vienna, October 17-21, 2004.

Yadroitsev, I., 2009. Selective laser melting: Direct manufacturing of 3D-objects by selective laser melting of metal powders. LAP Lambert Academic Publishing, Saarbrücken, Germany.

Yang, S. & Evans, J.R.G., 2003. Computer control of powder flow for solid freeforming by acoustic modulation. *Powder Technology*, 133, pp.251–254.

Yang, S. & Evans, J.R.G., 2007. Metering and dispensing of powder; the quest for new solid freeforming techniques. *Powder Technology*, 178 (1), pp.56–72.