

APPLICATION OF NUMERICAL MODELLING IN SSM AUTOMOTIVE BRAKE CALLIPER CASTINGS

N. JAHAJEEAH

National Product Development Centre, CSIR, Pretoria, South Africa
Email: njahajeeah@csir.co.za

ABSTRACT

Numerical modelling has successfully been used as an efficient tool to convert a gravity cast brake calliper to a thixocasting process. The thixo-module of Procast has been used for the modelling process to obtain optimum processing parameters. Results from interrupted shot castings show excellent correlation with the fluid dynamics and flow pattern of the model. The level and location of porosity revealed by non-destructive X-rays and microscopic analyses showed good correlation with the model prediction.

Keywords: Thixocasting, Thixo Modelling, Defect Prediction

1. INTRODUCTION

The Semi Solid Metal (SSM) processing route is developing into a mature high volume production method for components requiring superior structural integrity and mechanical properties, such as automotive fuel rails and master brake cylinders. This route is becoming increasingly attractive because heat fatigue of the die is reduced due to using a lower initial temperature. Better integrity of parts result from reduced shrinkage and porosity, energy usage is reduced and increased homogeneity of the microstructure of the castings are achieved. However, the SSM casting process typically requires tight process control as well as careful optimisation of the casting die design and process parameters. Numerical modelling of the SSM casting process can significantly reduce the time and cost required to develop and optimise new product applications. The aim of the present work was to apply numerical modelling of the SSM casting of an automotive brake calliper, which was initially designed for gravity die-casting. The modelling approach was validated through experimental trials.

2. BEHAVIOUR OF THIXOTROPIC MATERIALS

The attractiveness of using the SSM route comes from the fact that turbulence, porosity and shrinkage are considerably reduced. The fraction of liquid used in thixocasting processes typically ranges from 20-50% leading to a sufficiently high viscosity that prevents turbulent filling. The flow behaviour of a thixotropic casting is often difficult to predict because of its non-Newtonian rheology.

In general, increasing the temperature of a Newtonian fluid decreases the viscosity. For a thixotropic alloy, however, the viscosity decreases much faster because the viscosity of the multiphase alloy is greatly influenced by the liquid fraction. It is therefore necessary to control the liquid fraction and injection rate in order to avoid premature freezing, macro segregation and porosity.

During the filling stage of a die, the viscosity may drop by orders of magnitude as the “mushy” billet is deformed. This is often referred to as shear thinning. Concurrently, as the liquid phase starts to solidify, the viscosity of the material increases. Thus, both shear thinning and solidification effects are in competition during the filling stage.

At liquid fractions less than 20%, the thixotropic alloy can be treated as a solid with pockets of liquid [1]. At liquid fractions below 50%, the viscosity of the alloy increases rapidly reducing the turbulent flow behaviour. Due to the lower liquid fraction present, the risk of premature solidification and incomplete die filling increases. In the case of a thixotropic material, the viscosity decreases over time after an applied shear rate. The shear rate history dependent viscosity is therefore a critical factor in the design and casting processes. The viscosity should be high enough to reduce turbulent flows but low enough to allow all sections of the casting to fill completely before solidification occurs.

3. EXPERIMENTAL SET UP

The experimental die was set up on the Buhler H-400SC casting machine using conventional die set-up techniques. The die geometry and hydraulic cylinder system is shown in Figure 1. It consists of a horizontal shot sleeve with a velocity controlled piston system. The die is coated with a graphite-based lubricant to prevent the alloy from sticking to the die.



Figure 1:
Experimental die

A Magneto Hydro Dynamics (MHD) processed A356 aluminium alloy produced by SAG¹ was used for the experimental runs and the alloy was processed in the thixoforming route in order to ensure a homogenous and globular microstructure. Prior to casting, the billet is reheated in a horizontal induction furnace to a liquid fraction of 40-45%. The billet reheating profile is carefully controlled according to a previously optimised set up.

4. NUMERICAL MODELLING

Thixotropic materials have very complex thermo-mechanical behaviour because they are temperature dependent. Depending on the thermo-mechanical loading condition,

¹ Australian Company

the deformation of the liquid and solid phases can be either homogenous or heterogeneous. SSM behaviour can be modelled following two different approaches: the two phases [2] and the one phase approach. In the one phase approach, the thixotropic material behaves like a 'classical' and homogenous medium in which both solid and liquid have the same velocity. This method has a wider solidification interval from a volume solid fraction of zero up to one and is implemented in the Power Law Cut-Off model (PLCO) of Procast [3]. The PLCO model is based on the assumption that the material model is isotropic, its behaviour is purely viscoplastic and independent of pressure and that deformation is homogenous.

During a thixoforming process, no significant macroscopic liquid segregation occurs. The thixotropic material which consists of a partially solid and partially liquid phase can therefore be treated as a one phase model. The fluid flow is described by a Navier-Stokes model with a non-Newtonian viscosity function [4-5]. The temperature dependent shear thinning is approximated by a power law function as shown in equations (1) and (2) where μ is the local viscosity; μ_0 is the temperature dependent base viscosity, $\dot{\gamma}$ is the local shear rate, $\dot{\gamma}_0$ is the cut-off shear rate and n is the shear thinning exponent.

$$\mu(\dot{\gamma}, T) = \mu_0(T)\dot{\gamma}_0^{n(T)} \quad \dot{\gamma} \leq \dot{\gamma}_0 \quad (1)$$

$$\mu(\dot{\gamma}, T) = \mu_0(T)\dot{\gamma}^{n(T)} \quad \dot{\gamma} > \dot{\gamma}_0 \quad (2)$$

The shear history of the fluid is taken into account in this model by using a simple cut-off method. The latter is applied onto different identified shear regions. In such regions shear thinning will only occur if the shear rate cut-off value, $\dot{\gamma}_0$, is exceeded. On the other hand, if it is not exceeded the viscosity is not affected by local shearing and is calculated using $\dot{\gamma}_0$.

The brake calliper is divided into different domains of thixocasting material regions. One cut-off value of shear rate $\dot{\gamma}_0$ is applied to each sub domain as shown in Figure 2. The cut-off values $(\dot{\gamma}_0)_1$ and $(\dot{\gamma}_0)_2$ are stored for domains 1 (the gating system) and 2 (the brake calliper) respectively.

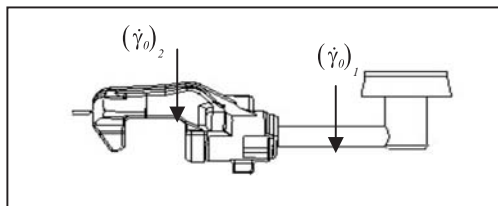

Figure 2: Cut-off values for domain 1 and 2

5. EXPERIMENTAL VALIDATION OF NUMERICAL MODEL

5.1 Fill Tests

The quality of a thixocasting process can be compromised if the processing parameters are not appropriate. For instance, a high piston velocity will introduce turbulence, a low billet temperature will lead to incomplete fill and a low die temperature will cause cold shut problems.

The three parameters chosen for optimisation were the billet temperature, the die temperature and the velocity of the piston. A sensitivity analysis of the billet temperature is used to establish the importance of the temperature at a given piston speed and die temperature. The sensitivity analysis of the piston velocity influences the metal flow pattern which needs to be controlled in order to obtain sound casting free of air entrapment. The optimum parameters were determined numerically with a billet temperature of 586°C, a die temperature 250°C and piston velocity of 0.18 ms⁻¹. These parameters were used as the basis for performing the experimental investigations to validate the numerical model. The dynamics and filling pattern of the model were validated by comparing with the results of interrupted filling tests. Figure 3 compares the results of interrupted tests between 0.41s and 0.95s. The fill tests compare favourably indicating the reliability of the fluid-dynamic model for a complex geometry.

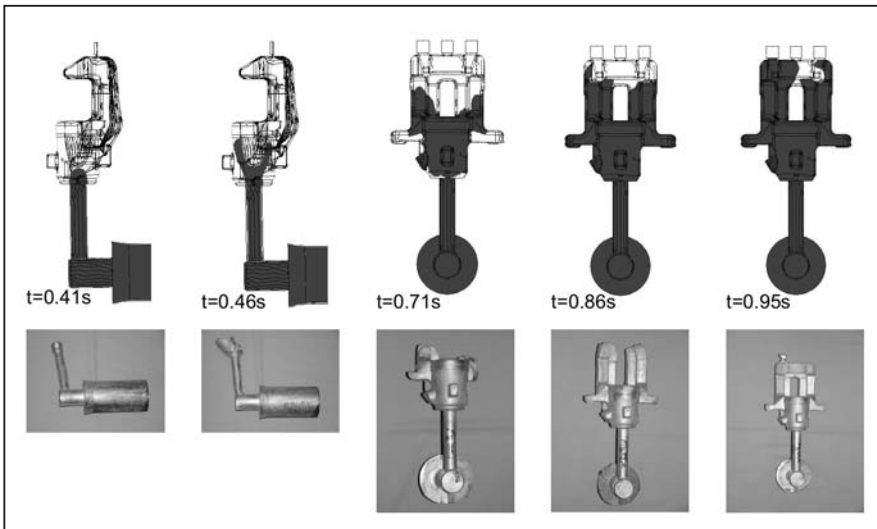

Figure 3: Comparison of interrupted filling tests

5.2 Defect Prediction

In order to validate the defect prediction capability of the model, an unoptimised gating system was considered. An ideal gating system consists of cross-section continuity to the part and allows for transmission of liquid metal for as long as necessary to the part [6]. Instead, a thin and long gating system was deliberately introduced and the numerical and experimental results compared.

The total filling time of the component is 1.01s. The temperature contour plot in Figure 4(a) shows premature solidification of the runner at 0.9s before filling is complete. A cross-section in the X-Y plane as in Figure 4(b) shows that a temperature of 576°C has already been reached in the gate.

The casting material is already in the solidus range making filling progressively more difficult. The low volume to surface area ratio of this runner implies a high cooling rate as the heat loss through the surface and the heat transfer coefficient is dependent on the interface pressure. The runner therefore solidifies before the part and restricts the transmission of pressure from the piston.

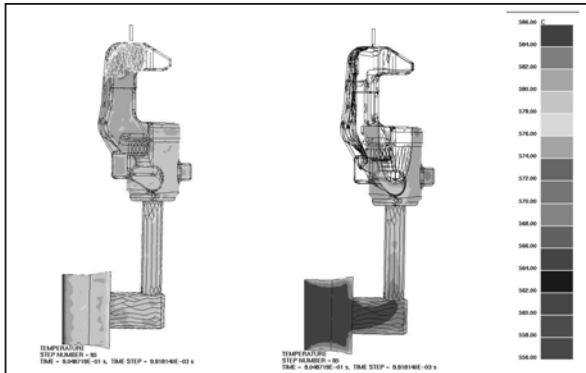

Figure 4: Temperature contour plot showing premature solidification

It is difficult to achieve adequate consolidation in the part resulting in porosity/shrinkage. Analysis of the solidification times and temperature contour plot from Figure 5 and Figure 6 show areas of hot spots which will result in prospective areas of shrinkage and porosity. The contour plot of Figure 7(a) confirms that shrinkage porosities do occur in the suspected areas.

Radiographic and microscopic analyses confirmed that the casting defects do in fact, arise from microscopic shrinkages or non-consolidated metal due to a low metal consolidation. The microstructure of the defects is shown in Figure 7(b) and Figure 7(c).

In regions where no casting defects are predicted, the casting is free of micro-porosity and non-metallic inclusions. The casting consists of globular aluminium primary crystals surrounded by fine aluminium-silicon eutectic as observed in Figure 7(d). The mean grain size is 82 microns which is very favourable for thixo-castability of the metal.

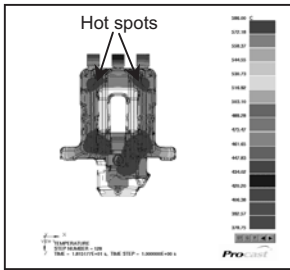

Figure 5: Areas of hot spots

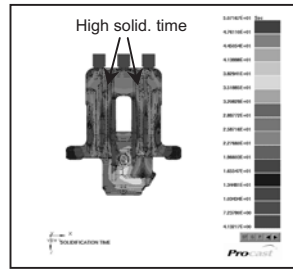

Figure 6: Solidification time

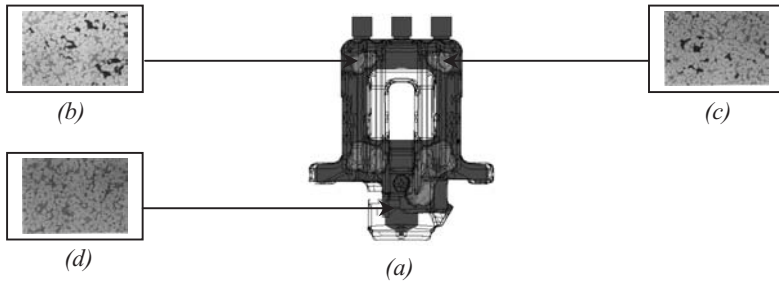

Figure 7: Contour plot of shrinkage porosity with micro structural results

6. CONCLUSIONS

Thixoforming simulation can provide relevant design input to the designer for appropriate die manufacture. Geometries of the gating system and component can be optimised using numerical simulations and potential casting defects and problems with gating/vents overflows can be predicted. Conventional gravity cast components can be successfully converted to the thixocasting process.

7. REFERENCES

- [1] Gunasekera, J. S., Proc. 2nd Conf. on Semi-Solid Processing of Alloys and Composites, MIT Press, Cambridge, MA, 211-222.
- [2] Modigell M., Koke J. and Petera J. (1998). Proc. of the 5th Int. Conf. on Semi-Solid Process of Alloys and Composites, Golden, Colorado, USA, 317.
- [3] Calcom SA, CTI Report, Project n.2942.1 (1997). Switzerland.
- [4] Paradis C. J., Rappaz M., Imwinkelried T. and Gabathuler J. P. (1997). Proc. 7th Conf. on Casting, Welding and Advanced Solidification Processes, San Diego, 933-940.
- [5] Imwinkelried (2000). Proc. 9th Conf. on Casting, Welding and Advanced Solidification Processes, Aachen, Germany.
- [6] Midson P. and Stephen (2000). Proc. 6th Conf on Semi-Solid Processing of Alloys and Composites, Turin, Italy, 67-71.