



Rapid Prototyping Journal

Effect of post-processing on the dimensional accuracy of small plastic additive manufactured parts
Joseph Nsengimana, Jacobus Van der Walt, Eujin Pei, Maruf Miah,

Article information:

To cite this document:

Joseph Nsengimana, Jacobus Van der Walt, Eujin Pei, Maruf Miah, (2019) "Effect of post-processing on the dimensional accuracy of small plastic additive manufactured parts", Rapid Prototyping Journal, Vol. 25 Issue: 1, pp.1-12, <https://doi.org/10.1108/RPJ-09-2016-0153>

Permanent link to this document:

<https://doi.org/10.1108/RPJ-09-2016-0153>

Downloaded on: 21 January 2019, At: 07:55 (PT)

References: this document contains references to 41 other documents.

To copy this document: permissions@emeraldinsight.com

The fulltext of this document has been downloaded 22 times since 2019*

Users who downloaded this article also downloaded:

(2019), "Influence of part's geometrical properties on shrinkage and laser heat affected zone size at selective laser sintering", Rapid Prototyping Journal, Vol. 25 Iss 1 pp. 208-220 https://doi.org/10.1108/RPJ-01-2018-0032

(2019), "A statistical method for build orientation determination in additive manufacturing", Rapid Prototyping Journal, Vol. 25 Iss 1 pp. 187-207 https://doi.org/10.1108/RPJ-04-2018-0102



Access to this document was granted through an Emerald subscription provided by eabrpj

For Authors

If you would like to write for this, or any other Emerald publication, then please use our Emerald for Authors service information about how to choose which publication to write for and submission guidelines are available for all. Please visit www.emeraldinsight.com/authors for more information.

About Emerald www.emeraldinsight.com

Emerald is a global publisher linking research and practice to the benefit of society. The company manages a portfolio of more than 290 journals and over 2,350 books and book series volumes, as well as providing an extensive range of online products and additional customer resources and services.

Emerald is both COUNTER 4 and TRANSFER compliant. The organization is a partner of the Committee on Publication Ethics (COPE) and also works with Portico and the LOCKSS initiative for digital archive preservation.

*Related content and download information correct at time of download.

Effect of post-processing on the dimensional accuracy of small plastic additive manufactured parts

Joseph Nsengimana

Department of Mechanical and Mechatronics Engineering, Central University of Technology, Free State, Bloemfontein, South Africa and Department of Mechanical Engineering, University of Rwanda-College of Science and Technology (UR-CST), Kigali, Rwanda

Jacobus Van der Walt

Department of Mechanical and Mechatronics Engineering, Central University of Technology, Free State, Bloemfontein, South Africa

Eujin Pei

Department of Design and Physical Sciences, College of Engineering, Brunel University London, London, UK, and

Maruf Miah

CAD Design, De Montfort University, Leicester, UK

Abstract

Purpose – This paper aims to investigate the effect of post-processing techniques on dimensional accuracy of laser sintering (LS) of Nylon and Alumide[®] and fused deposition modelling (FDM) of acrylonitrile butadiene styrene (ABS) materials.

Design/methodology/approach – Additive manufacturing (AM) of test pieces using LS of Nylon and Alumide[®] powders, as well as the FDM of ABS materials, were first conducted. Next, post-processing of the test pieces involved tumbling, shot peening, hand finishing, spray painting, CNC machining and chemical treatment. Touch probe scanning of the test pieces was undertaken to assess the dimensional deviation, followed by statistical analysis using Chi-square and Z-tests.

Findings – The deviation ranges of the original built parts with those being subjected to tumbling, shot peening, hand finishing, spray painting, CNC machining or chemical treatment were found to be different. Despite the rounding of sharp corners and the removal of small protrusions, the dimensional accuracy of relatively wide surfaces of Nylon or Alumide[®] test pieces were not significantly affected by the tumbling or shot peening processes. The immersion of ABS test pieces into an acetone bath produced excellent dimensional accuracy.

Research limitations/implications – Only Nylon PA2200 and Alumide[®] processed through LS and ABS P400 processed through FDM were investigated. Future work could also examine other materials and using parts produced with other AM processes.

Practical implications – The service bureaus that produce prototypes and end-use functional parts through AM will be able to apply the findings of this investigation.

Originality/value – This research has outlined the differences of post-processing techniques such as tumbling, shot peening, hand finishing, spray painting, CNC machining and chemical treatment. The paper discusses the advantages and disadvantages of each of those methods and suggests that the immersion of ABS test pieces into an acetone bath produced excellent dimensional accuracy.

Keywords Selective laser sintering, Fused deposition modelling, Dimensional accuracy, Post-processing, Nylon Alumide[®] ABS

Paper type Research paper

1. Introduction

Additive manufacturing (AM) is defined as a process of joining materials to make objects from 3D model data, usually layer-upon-layer, as opposed to subtractive manufacturing (De Beer, 2013 and Manfredi *et al.*, 2014). Depending on the type of technology, powder, liquid or solid based materials are used for AM processes. Although several AM technologies exist, all of them have five common steps. A digital 3D model is created

using a computer-aided design (CAD) package. Next, the CAD model is converted into Standard Tessellation Language (STL) format. The STL file is sliced into Two-Dimensional

This research was supported by Central University of Technology, Free State (CUT) through the Centre for Rapid Prototyping and Manufacturing (CRPM) and Product Development Technology Station (PDTs) and De Montfort University (UK). The authors acknowledge also the support of University of Rwanda-College of Science and Technology (UR-CST). Funding for this work was made available by the South African Research Chairs Initiative of the Department of Science and Technology and National Research Foundation of South Africa (Grant №97994) and the Collaborative Program in Additive Manufacturing (Contract №CSIR-NLC-CPAM-15-MOA-CUT-01).

Received 22 September 2016

Revised 17 February 2017

14 May 2017

Accepted 3 July 2017

The current issue and full text archive of this journal is available on Emerald Insight at: www.emeraldinsight.com/1355-2546.htm



Rapid Prototyping Journal
25/1 (2018) 1–12
© Emerald Publishing Limited [ISSN 1355-2546]
[DOI 10.1108/RPJ-09-2016-0153]

(2D) thin cross sectional layers in x-y plane which represent contours of the part. The 3D physical object is then constructed one layer atop each other, but not as a continuous z-coordinate, thus forming a stair-stepping effect in the z-direction (Latiff *et al.*, 2013) until the part is completely built. Finally, the built model is removed from the machine, cleaned, and any supports removed depending on the AM technology used. Depending on the desired surface finish, the part may be further subjected to post-processing techniques to improve its surface mechanical properties or to obtain a better aesthetic appearance. Figure 1 summarizes the steps involved that are common to most AM processes.

2. Laser sintering process for plastic materials

Laser sintering (LS) is an AM process in which powdered material is fused by using laser energy to produce parts. Figure 2 shows the layout of an EOS P385 machine as an example. Plastic powder with particle size ranging from 20 to 100 μm in diameter is stored in the powder supply bins. The recoater is filled with powder when positioned under one of the bins and deposits a layer of powder with a thickness of 150 μm when moved across the platform. As it stops under the opposite bin, it is again filled with powder. A laser in continuous or pulse mode scans 2D slices of the design onto the powder and in the process generates the required heat for fusing the powder

Figure 1 Flow chart of AM processes

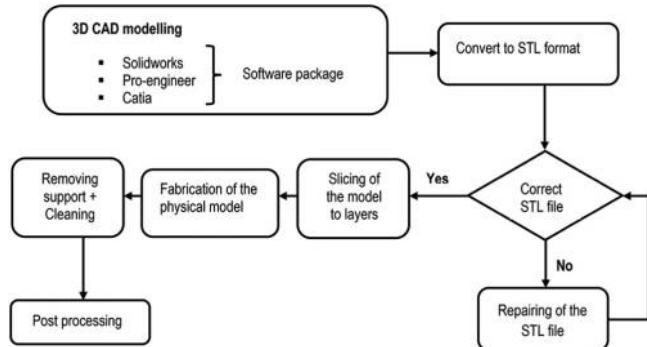
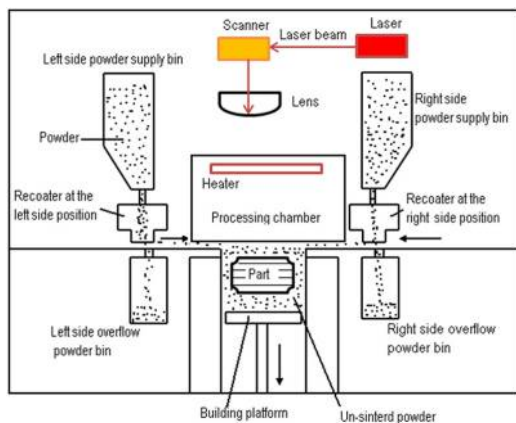

Figure 2 LS process for EOS P385 machine



particles. The build platform is lowered one-layer thickness, a new layer of powder is deposited and the next slice of the design is scanned by the laser. This process is repeated until the part is completed. The excess powder from recoating falls into the overflow bins in a compartment below the build chamber (EOS GmbH, 2005). The un-sintered powder surrounding the parts is cleaned away and can be largely recycled together with the overflow powder once the build is completed. Support structures are not required with the LS process as the un-sintered powder supports the part during manufacturing.

3. Surface finish and dimensional accuracy of laser sintered Nylon and Alumide® parts

In commercial practices, it is not economical to use only virgin powder in the LS process. A mixture of virgin and used powders is recommended to compensate the high purchasing cost of the virgin powder and to minimize waste. Kruth *et al.* (2008) noted that long exposure of the polymer powder to heat when reused for further fabrication causes non-constant consolidation conditions and a shift in the melting temperature, causing a drop in powder flowability and a rise in melt viscosity, thus preventing good sintering quality. This can be a potential source of rough surface and dimensional inaccuracy after a certain number of cycles of the used powder. The use of a mixture of 70 per cent virgin and 30 per cent re-used powder was recommended to produce parts with acceptable quality. Pham *et al.* (2008) investigated the significance of the Mass Flow Rate (MFR) on the surface quality of laser sintered Nylon PA2200 parts. It was found that the higher the MFR, the better the powder quality, thus leading to the production of parts with good surface finish and accurate dimensions. They recommended to consider a MFR higher than 25–27 g/10 min when mixing and blending used and new Nylon PA2200 powders to produce good quality parts. To avoid static forces which can hinder the spreading of the powder during the sintering process and causing unwanted sintering adjacent to the desired area thus affecting negatively the accuracy of the part, Goodridge *et al.* (2012) recommended 45 to 90 μm as an optimal range of particle sizes for LS of macro parts. Shirazi *et al.* (2015) mentioned that although high energy density leads to good mechanical properties of the laser sintered parts; it can sometimes lead to inaccurate dimensions. Very little information is available in literature on improving the surface finish of laser sintered Alumide® parts, except using conventionally accepted techniques such as tumbling (De Beer *et al.*, 2012), grinding, polishing and filing techniques (Urednik, 2013).

4. Overview of the fused deposition modelling process

Fused deposition modelling (FDM) is a process which creates models where each layer is built by deposition of molten thermoplastic or wax material in the form of a filament available in spools or cartridges (Daneshmand *et al.*, 2013). The nozzle of the FDM machine is heated and a thin filament of molten material is extruded and deposited onto the build platform according to the first layer of the slice file as shown in Figure 3. As the air surrounding the head is maintained at a temperature

Figure 3 FDM process

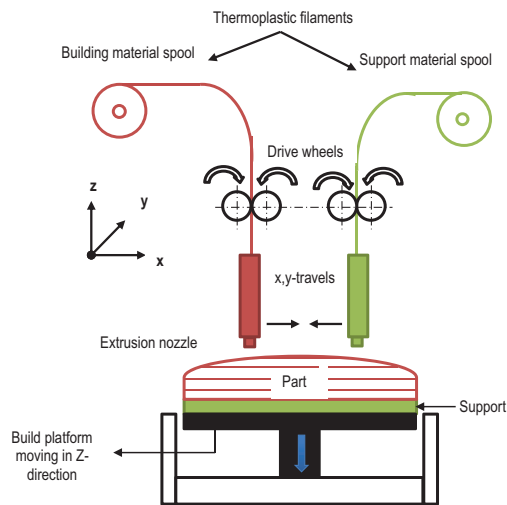

which is below the material's melting point, the molten material quickly solidifies. The extrusion nozzle controlled by a CAM software that can move in the horizontal (x-y plane). When the first layer is completed, the building platform is lowered by one-layer thickness (z-axis) and the next layer is deposited. The process continues until the entire part is built. Support structures which are built during the process to support overhanging structures of parts can be later removed manually. When water soluble supports are used, they may simply be dissolved with the latter approach being most efficient for complicated geometries (Daneshmand and Aghanajafi, 2012).

FDM printers support the use of acrylonitrile butadiene styrene (ABS) plastics which are also frequently used in medical and automotive applications. Materials such as polycarbonate (PC), methyl methacrylate acrylonitrile-butadiene styrene (ABSi), polyphenyl sulfone (PPSF) and other blends of ABS (ABS-M30, ABS M30i, ABS-Plus, ABS-PC and ABS-P400) are also used for manufacturing parts through FDM technology (Mireles et al., 2011).

5. Surface finish and dimensional accuracy of fused deposition modelled acrylonitrile butadiene styrene parts

Easy operation, inexpensive machinery, short building time, easy material changeability and good mechanical properties are advantages of FDM technology, rendering it the most popular AM method when compared to other processes such as Stereolithography (SLA), LS or Polyjet used for production of plastic parts (Noriega et al., 2013). Despite the above mentioned advantages of the FDM process, the poor surface finish and dimensional inaccuracy of parts resulting from this process is its main disadvantage (Krolczyk et al., 2014; Dzullijah et al., 2014; Akande, 2015 and Garg et al., 2017). As there is no single method of improvement of surface finish, Bual and Kumar (2014) highlighted that optimization of build orientation, slicing strategy (layer thickness), fabrication parameters optimization and post-processing treatments are the four most commonly accepted methods which can be used

separately or in combination to reduce the surface roughness of AM components. Figure 4 shows the geometrical process parameters of FDM technology, which influence the surface finish and the dimensional accuracy of manufactured parts.

Layer thickness and the raster width greatly influence the dimensional accuracy and the quality of the surface finish of ABS parts being produced through the FDM process. Air gaps were shown to have a significant effect on the dimensional accuracy while it has little influence on the surface finish (Nancharaiyah, et al., 2010). Noriega et al. (2013) used an artificial neural network combined with an optimization algorithm to determine dimensional values of CAD model for the FDM process. Application of this methodology achieved a reduction in manufacturing error of approximately of 50 and 30 per cent for external and internal dimensions respectively. McCullough and Yadavalli (2013) reported that improvement of the surface characteristics of the FDM process is one of the significant challenges to adopt ABS for medical applications. To ensure that an FDM component is completely watertight, they soaked the printed channels into a 25 per cent concentrated acetone bath. Soaking of the components for periods varying from 1 to 8 h in an aqueous solution of concentration ranging from 40 to 60 Vol.% acetone was found to be optimal to ensure that the surface becomes watertight and yet still preserving the microstructure of the component. An increase from 7 nm to 9 nm of surface roughness over an initial 5 μm area was observed. The removal of ABS material during an acetone soak caused pitting and subsequent deposition of ABS on the surface formed peaks. To improve the surface quality of a tool fabricated from ABS using

Figure 4 Geometrical process parameters of FDM technology

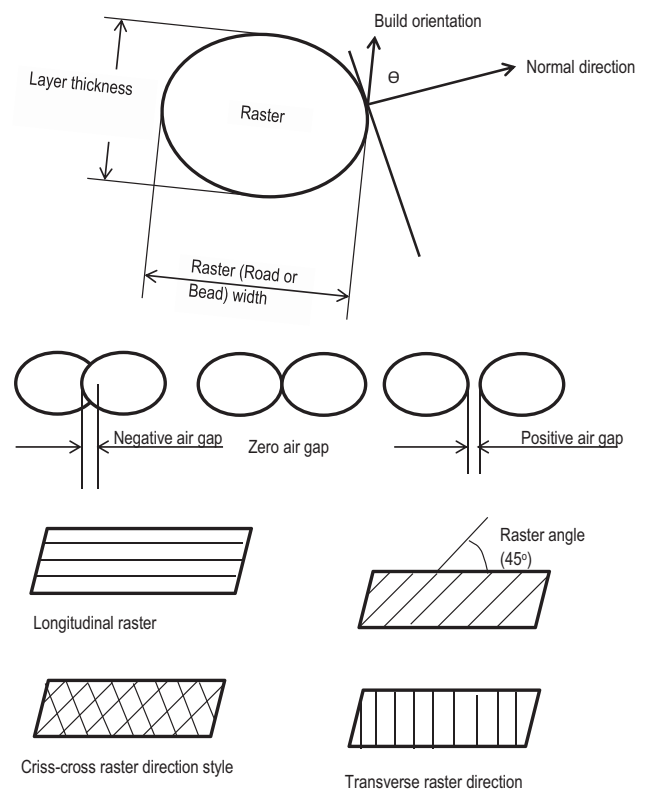

the FDM process, Kuo and Su (2013) used a vibratory filling mechanism where a mixture of a composite aluminium powder (70 per cent) and epoxy liquid resin (30 per cent) was used as a filling material to eliminate the parabolic surface profile of the tool. The surface finish was improved from 1710 to 276 $\mu\text{m Ra}$. Galantucci et al. (2015) carried out a comparative study of the dimensional accuracy of two FDM machines namely an open-source Fab@Home Model 1 and a Stratasys FDM 3000 machine. The factorial analysis design of experiment to optimize the process parameters for improvement of the dimensional accuracy of ABS-P400 test pieces was used. It was found that for a rectangular specimen of length $L_1 = 18$ mm; width $L_2 = 18$ mm and height $H = 8$ mm, the manufactured specimens showed a percentage error of -0.2 per cent on L_1 , $+0.1$ per cent on L_2 and $+1.9$ per cent on H for FDM 3000 system; and -0.9 per cent on L_1 , -0.7 per cent on L_2 and $+3.2$ per cent on H for the open-source system. They attributed the negative errors in lateral dimensions to be caused by the material shrinkage while the increase in height was caused by issues with the raft layer. Raja (2016) indicated that metallization, electroplating, vapour deposition, thermal coating, electroless plating or autocatalytic plating and electrochemical polishing are other chemical processes that can be used to improve the surface characteristics of AM plastics. Singh and Singh (2017) improved the surface finish of ABS replicas by optimizing input parameters of FDM, followed by chemical vapour smoothing (CVS) treatment. Though the CVS process applied for a cycle of time of more than 10 s almost eliminated the stair-step effect on the surfaces, significant deviations in some dimensions of the specimens were observed. Garg et al. (2016) and Garg et al. (2017) investigated the effect of improving the surface finish of FDM ABS specimens using cold vapour and hot vapour of acetone and lukewarm acetone on dimensional accuracy and mechanical properties of the parts. Despite the relative long exposure time (40 minutes), cold vapour of acetone produced uniform surfaces.

Extensive research has been done on improvement of the surface finish and its subsequent effect on the dimensional accuracy of LS and FDM parts using the process of parameter optimization (Zarringhalam et al., 2006; Raghunath and Pandey, 2007; Anoop et al., 2009; Shrivastava et al., 2010; Anoop et al., 2011; Tanay et al., 2013; Bual and Kumar, 2014; Daneshmand et al., 2013; Singh, 2013; Lieneke et al., 2016 and Kitsakis et al., 2016). However, the obtained surface finish of LS or FDM parts could not achieve the required surface finish quality for end use functional parts, thus rendering post-processing techniques through mechanical or chemical treatments a necessity for the AM industry. To the best knowledge of the authors, very little research is available in literature on the assessment of the detrimental effects of post-processing techniques on the dimensional accuracy of AM parts.

6. Dimensional accuracy of post-processing techniques

6.1 Description and manufacturing of test pieces

A test piece (Figure 5) was designed to investigate the effect of different post-processing techniques on small plastic parts manufactured through AM in terms of surface roughness and geometrical accuracy. The test piece was designed using SolidWorks software to have a base size of 60×60 mm² with a

Figure 5 Test piece and its features

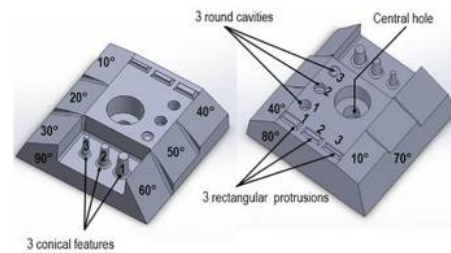

height of 19.20 mm. The designed test piece had different planar surfaces with inclination angles varying from 0° (horizontal) to 90° (vertical) with an increment of 10°. This was to show the variation of the stair-step effect as a result of the AM processes with different inclination angles and to investigate the effect of the different post-processing techniques on this. For each surface finishing technique, four standard test pieces were manufactured through LS using Nylon polyamide PA2200 and Alumide® powders and through FDM using ABS P400 thermoplastic as a feedstock material. In addition to this, one test piece was manufactured in each material that would serve as reference test piece, in the form of a control. In particular, the test pieces for CNC machining was designed slightly over sized at $60.72 \times 60.72 \times 19.56$ mm³ to allow the milling of a thin layer from each of the surfaces. The test piece design incorporated small features in the form of truncated cones, protruding rectangles and round cavities for comparative investigation of the effects of different post-processing techniques. A central hole was provided for clamping of the test piece during hand finishing, spray painting and CNC machining operations. Table I shows the process parameters used for manufacturing the Nylon, Alumide® and ABS test pieces.

6.2 Touch probe scanning process

A Renishaw® Cyclone RG24 Coordinate Measuring Machine (CMM) with a ruby ball stylus of 2 mm diameter and a scanning rate up to 140 points per second with a resolution of 0.1 mm was used to investigate the dimensional accuracy of the AM test pieces compared to the original CAD geometry, as well as to investigate the effects of the six post-processing techniques on the dimensional accuracy of the AM test pieces. The “as-built” Nylon, Alumide® and ABS test pieces were scanned, followed by one test piece from each post-processing technique and the results were recorded as a point cloud and then converted to STL file with the Trace scan 24A software. For each material, the STL file was processed using the Geomagic Qualify software where the dimensions of the “as-built” test pieces were compared to the geometric dimensions of the original CAD design. For each scanned sample, with a nominal deviation range of ± 0.1 mm, the 3D scanning technology of Geomagic Qualify software generates a colour map (Figure 6) with the corresponding deviation ranges and produces a statistical report.

It can be observed (Figure 6) that within a resolution of 0.1 mm, the negative deviation ranges (from -0.348 to -0.1) mm that appear differently on the surfaces of the Nylon, Alumide® and ABS test pieces may have been caused by the shrinkage of the materials due to the solidification process. Positive deviation ranges (0.1 to 0.348) mm are

Table I Process parameters for AM of the test pieces

Process parameters	LS		FDM
Materials	Nylon PA2200	Alumide®	ABS P400 (white)
Machine	EOS P385	EOS P385	Dimension SST 1200
Average grain size (μm)	56	60	
Raster width (mm)			0.5
Average melting point ($^{\circ}\text{C}$)	172-180	172-180	
Laser power (W)	48	48	
Scanning speed (mm/s)	4500	4500	
Part bed temperature ($^{\circ}\text{C}$)	177.5	179	
Layer thickness (μm)	150	150	254
Part build orientation ($^{\circ}$)	0	0	0
Build rate (mm/hour)	20	20	
Mass flow rate (g/10 min)	30	30	
Scaling factor in x, y and z-directions	1.0229; 1.030 and 1.018	1.0229; 1.030 and 1.018	1
Model interior			Solid-Normal
Support fill			Sparse

Figure 6 Dimensional accuracy of “as-built” nylon (a), Alumide® (b) and ABS (c) test pieces compared to CAD geometry

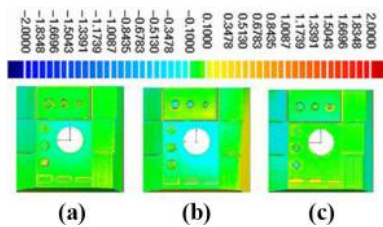

also observed, especially at a 10° surface angle where the stair-step effect is more pronounced and at the areas close to small features (protrusions, round cavities and conical features). This positive deviation may have been caused by the inability of the 2 mm diameter stylus to enter the grooves

between adjacent steps or to move close to the basis of the small features.

6.3 Post-processing techniques

To establish the significance level of the change in the geometry of plastic parts manufactured through LS and FDM processes when post-processing techniques were applied for improvement of the surface finish, six post-processing techniques were performed on the Nylon, Alumide® and ABS test pieces as summarized in Table II.

The results are discussed in the next section.

7. Results of experiments

7.1 Preliminary statistical results

Prior to the touch probe scanning process, it was observed that the chemically treated Nylon and Alumide® test pieces showed

Table II Post-processing techniques and procedures applied to test pieces

Post-processing technique	Material for test pieces		
	Nylon	Alumide®	ABS
Tumbling	Vibrating the test four pieces together with small abrasive stones wetted by a soapy liquid at rotation speeds of 1500 rpm for durations of 1.5, 3, 4.5 and 6 h respectively		Similar process as for nylon and Alumide® but for a duration of 1, 2, 3 and 4 h
Shot peening	Blasting the four test pieces with small stainless steel balls of 0.5 mm diameter propelled by compressed air at 5 Bar for durations of 2, 4, 6 and 8 min respectively	Similar process as for nylon but for a duration of 1, 2, 3 and 4 min	Similar process as for nylon but for a duration of 2, 4, 6 and 8 min
Hand finishing	Sanding and priming the four test pieces for 45 min. This was repeated for three of the test pieces followed by an additional 25 min sanding and priming for two test pieces. Lastly one test piece received a final 25 min sanding and priming		
Spray painting	Progressive build-up of one additional layer of primer for each test piece, i.e. first test piece 1 layer, 2 nd two layers etc. All finished with one coat of silver paint each		
CNC machining	Cutting tool	3 mm diameter ball cutter	
	Rotation speed of the spindle	4000 rpm	
	Feed rate	600 mm/min	
	Step-over	0.2 mm	
	Cutting depth	0.3 mm	
Chemical treatment			Immersion into acetone bath at room temperature for a duration of 60 s

that neither acetone, formic acid nor resorcinol acid dissolved the surfaces of the test pieces; hence only a chemically treated ABS test piece was touch probe scanned. Preliminary statistical data generated by Geomagic Qualify[®] software for Nylon, Alumide[®] and ABS touch probe scanned test pieces were categorized into 24 deviation ranges to cover a range from -2.000 to +2.000 mm. Figures 7, 8 and 9 show the comparison of dimensional accuracy of post processed test pieces, referenced to the geometry of the “as-built” Nylon, Alumide[®] and ABS test pieces.

Figure 7 Comparison of dimensional accuracy of post-processing techniques for nylon test pieces

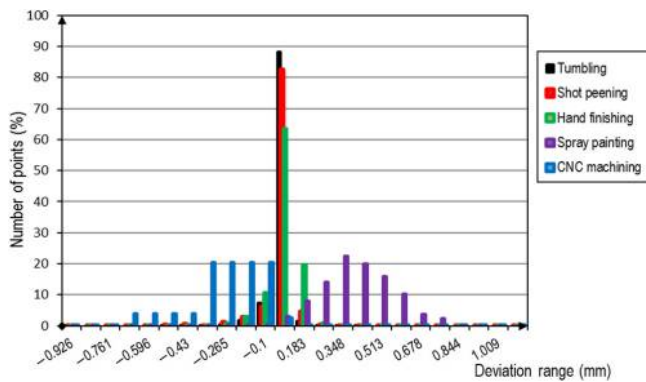

Figure 8 Comparison of dimensional accuracy of post-processing techniques for Alumide[®] test pieces

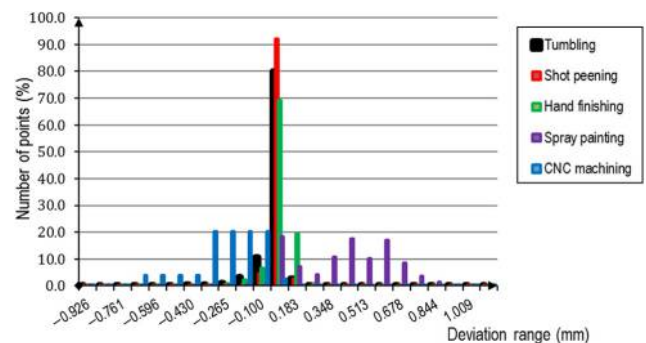
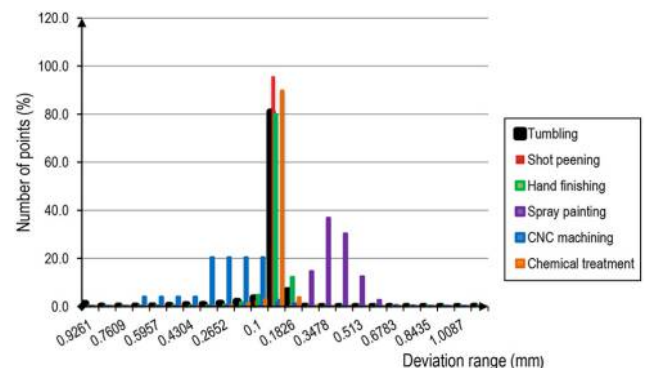

Figure 9 Comparison of dimensional accuracy of post-processing techniques for ABS test pieces



7.2 Visual inspection of touch probe scanned test pieces

The images along with the colour map generated by Geomagic Qualify[®] software enabled the visualization of the effects of each post-processing technique on the geometry of the “as-built” Nylon, Alumide[®] and ABS test pieces.

With ±0.1 mm resolution, Figures 10-12 show the images obtained for post processed test pieces.

8. Analysis of results, observations and conclusions

8.1 Test of homogeneity between “as-built” and post-processing techniques

In addition to preliminary statistical results, there is a need of having a quantitative comparative measure to assess the extent to which the proportions of deviation ranges for “as-built” and for any post-processing technique are the same. For this purpose, a Chi-square test denoted by χ^2 , for a null hypothesis H_0 : the

Figure 10 Touch probe scan of Nylon test pieces: “as-built” compared to CAD geometry (a), tumbled (b), shot peened (c), hand finished (d), spray painted (e) and CNC machined (f) compared to “as-built” geometry

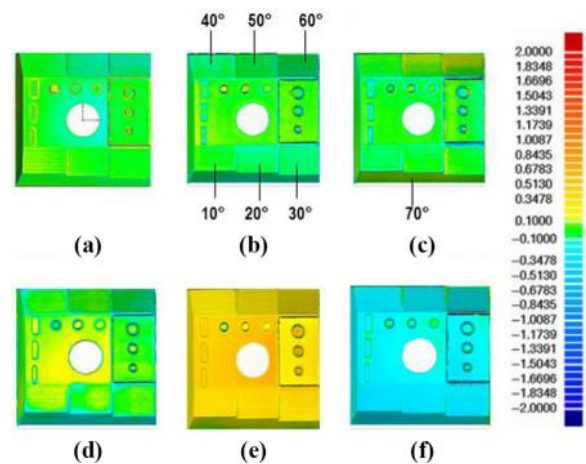

Figure 11 Touch probe scan of Alumide[®] test pieces: “as-built” compared to CAD geometry (a), tumbled (b), shot peened (c), hand finished (d), spray painted (e) and CNC machined (f) compared to “as-built” geometry

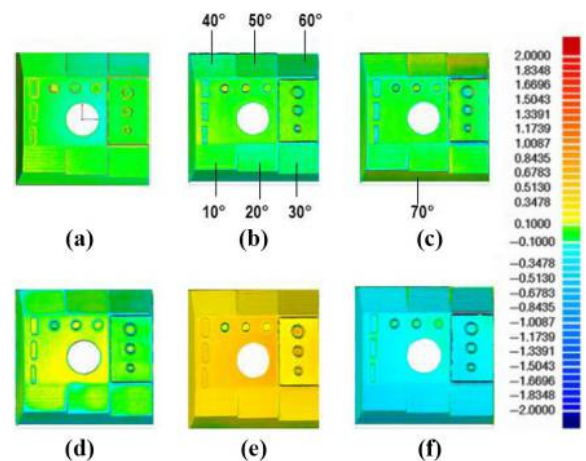
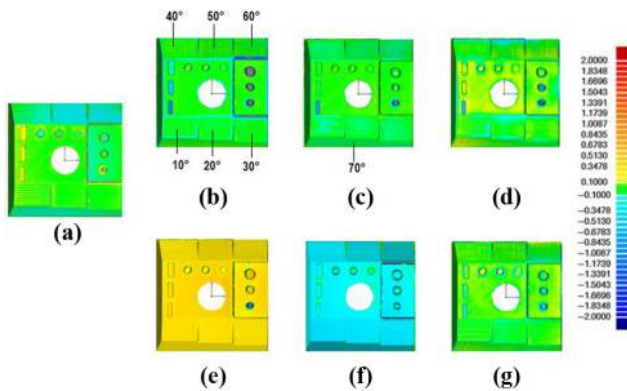

Figure 12 Touch probe scan of ABS test pieces: “as-built” compared to CAD geometry (a), tumbled (b), shot peened (c), hand finished (d), spray painted (e), CNC machined (f) and chemically treated (g) compared to “as-built” geometry



proportions of deviation ranges are the same as one compares “as-built” to any one of the post-processing techniques; and with different significance levels $\alpha = 0.002; 0.01; 0.05; \text{ and } 0.1$ is used. Applying the CHSQ.TEST function available in Microsoft Excel spread sheet, the probability (p -value) of observing a value of Chi-square χ^2 at least as large as the observed value when H_0 is true; or in other words the smallest value of α for which H_0 that can be rejected was calculated. A conclusion was reached by comparing the calculated p -value to the significance level α for the test. For all three investigated materials and for all six investigated post-processing techniques, the p -value was obtained equal to zero, implying the rejection of the null hypothesis for all post-processing techniques.

8.2 Test for the difference in population proportions

To establish which deviation range proportion (row) is significantly larger or smaller compared to the proportion of “as-built” versus any post-processing technique’s proportion (columns), it is needed to test for the differences in population (treatment) proportions for each individual deviation range to both “as-built” and tumbling for example. For each deviation range, the test statistic Z -observed (Z_{obs}) calculated from the observed proportions will be compared to the value of the Inverse Normal Distribution, denoted $Z_{\alpha/2}$ (Figure 13), associated with the level of significance $\alpha/2$. H_0 , there is no difference in the true proportions of “as-built” test piece versus tumbled test piece for example, is rejected if $Z_{obs} < -Z_{\alpha/2}$ or $Z_{obs} > Z_{\alpha/2}$.

The Z -test for differences in population proportions indicated that there existed a number of deviation ranges where H_0 was not rejected, i.e. there was no difference in proportions of the number of points for both “as-built” and a post-

Figure 13 Standard normal z-curve for a significance level $\alpha = 0.002$

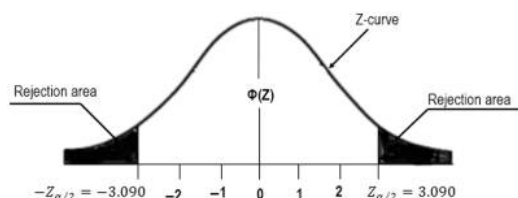

processing technique. Tables III–V highlight the deviation ranges for which H_0 is true, along with the percentage of number of observed points.

8.3 Discussion and interpretation of results

The computation of the Chi-square test for “as-built” compared to tumbling, shot peening, hand finishing, spray painting, chemical treatment and CNC machining post-processing techniques gives a p -value = 0 for each of the post-processing techniques for the Nylon, Alumide[®] and ABS test pieces. As the p -value is less than all the significance levels 0.002; 0.01; 0.05 and 0.1 for the test, H_0 is rejected for all post-processing techniques for all significant levels. This indicates that there are significant differences in the proportions of all the deviation ranges (rows) as one compares the “as-built” test pieces to tumbled, shot peened, hand finished, spray painted, chemically treated or CNC machined test pieces (columns). However, the test statistic Z -observed (Z_{obs}) for differences in population proportions indicates that there exist a number of deviation ranges where H_0 is not rejected, i.e. there is no difference in proportions of the number of points for both “as-built” and a post-processing technique. For the “as-built” and other post-processing techniques, it is observed that the population proportions are the same in extreme positive or negative deviation ranges where a very small number of points (0 or 0.1 per cent) is found to fall into such deviation ranges. It can be observed from Tables III–V that for all three investigated materials, the increase of significance levels from 0.002 to 0.01, 0.05 and 0.1 has a little effect on the number of deviation ranges where no difference in population is observed. This indicates that the Z -test confirms that, for nylon, Alumide[®] and ABS test pieces, there exist strong evidences to conclude that the proportions in deviation ranges are not the same when one compares the “as-built” part versus tumbling, shot peening, hand finishing, spray painting, CNC machining or chemical treatment post-processing techniques applied to the test pieces.

Figures 14, 16, 17, 18 and 20 show the qualitative progressive dimensional deviations of the geometry of the post processed Nylon, Alumide[®] and ABS test pieces from “as-built” test piece. Due to the limitations on time and funds, the touch probe scan was only performed on the “as-built” and on the final post processed test pieces.

Within the ± 0.1 mm deviation range from the “as-built” test piece, with a good uniform distribution of ± 0.1 mm deviation ranges across the relatively wide surfaces of the test piece, the tumbling technique applied progressively from 1.5 hour up to 6 hours with an increment of 1.5 hour, to both Nylon and Alumide[®] (Figure 14); and applied progressively from 1 hour to 4 hour with an increment of 1 hour to ABS test pieces, produced very good dimensional accuracy. 88.3 per cent, 80.1 per cent and 81 per cent of the total number of touch probe scanned points on the surfaces of the test pieces were achieved for the nylon, Alumide[®] and ABS test pieces respectively (Figures 7–9). For all three materials, the tumbling technique was characterized by the rounding of sharp corners, wearing away of small protrusions, and the breaking off of the conical features [Figures 10(b), 11(b), 12(b) and 14(c)]. Significant delamination of fibres from FDM part at the areas with sharp edges is particularly observed with the tumbling of ABS test pieces (Figure 15).

Table III Deviation ranges with no difference in population for nylon test pieces

Post-processing techniques	Significance levels				% of observed no. of points For "as-built" p1 × 100 For the process p2 × 100					
	$\alpha = 0.002$ (99.8%), $Z_{\alpha/2} = 3.090$ Deviation ranges (mm)	$\alpha = 0.01$ (99%), $Z_{\alpha/2} = 2.575$ Deviation ranges (mm)	$\alpha = 0.05$ (95%), $Z_{\alpha/2} = 1.960$ Deviation ranges (mm)	$\alpha = 0.1$ (90%), $Z_{\alpha/2} = 1.645$ Deviation ranges (mm)						
Tumbling	-0.926	-0.844	-0.926	-0.844		0	0			
	-0.844	-0.761	-0.844	-0.761	-0.844	-0.761	0	0		
	0.926	1.009	0.926	1.009			0	0		
	1.009	2	1.009	2	1.009	2	1.009	2.000	0	0
Shot peening	0.926	1.009						0	0	
Hand finishing	-0.926	-0.844						0	0	
	0.926	1.009	0.926	1.009	0.926	1.009	0.926	1.009	0	0
	1.009	2	1.009	2	1.009	2.000			0	0
Spray painting	-2	-0.926	-2	-0.926	-2.000	-0.926	-2.000	-0.926	0	0
	-0.926	-0.844	-0.926	-0.844	-0.926	-0.844	-0.926	-0.844	0	0
	-0.844	-0.761	-0.844	-0.761	-0.844	-0.761	-0.844	-0.761	0	0
	-0.761	-0.678	-0.761	-0.678	-0.761	-0.678	-0.761	-0.678	0	0
	-0.678	-0.596	-0.678	-0.596	-0.678	-0.596			0	0
	-0.596	-0.513	-0.596	-0.513	-0.596	-0.513			0	0
	-0.513	-0.43	-0.513	-0.43	-0.513	-0.430	-0.513	-0.430	0	0
							-0.430	-0.348		
CNC machining	-2	-0.926	-2	-0.926	-2.000	-0.926	-2.000	-0.926	0	0
	-0.926	-0.844	-0.926	-0.844	-0.926	-0.844	-0.926	-0.844	0	0
	-0.844	-0.761	-0.844	-0.761	-0.844	-0.761	-0.844	-0.761	0	0

Notes: p1: proportion of points for a given deviation range for "as built" test piece; p2: proportion of points for a given deviation range for post processed test piece; z_{α} : value for inverse normal distribution associated with the level of significance alpha

Table IV Deviation ranges with no difference in population for Alumide® test pieces

Post-processing techniques	Significance levels				% of observed no. of points For "as-built" p1 × 100 For the process p2 × 100					
	$\alpha = 0.002$ (99.8%), $Z_{\alpha/2} = 3.090$ Deviation ranges (mm)	$\alpha = 0.01$ (99%), $Z_{\alpha/2} = 2.575$ Deviation ranges (mm)	$\alpha = 0.05$ (95%), $Z_{\alpha/2} = 1.960$ Deviation ranges (mm)	$\alpha = 0.1$ (90%), $Z_{\alpha/2} = 1.645$ Deviation ranges (mm)						
Tumbling	-0.926	-0.844	-0.926	-0.844		0	0			
	-0.844	-0.761	-0.844	-0.761		0	0			
Shot peening	-0.926	-0.844	-0.926	-0.844	-0.926	-0.844	-0.926	-0.844	0	0
	-0.844	-0.761	-0.844	-0.761	-0.844	-0.761			0	0
	-0.678	-0.596							0	0
Hand finishing	-2	-0.926	-2.000	-0.926	-2.000	-0.926	-2.000	-0.926	0	0
	-0.926	-0.844	-0.926	-0.844	-0.926	-0.844	-0.926	-0.844	0	0
	-0.844	-0.761	-0.844	-0.761					0	0
	-0.761	-0.678	-0.761	-0.678					0	0
Spray painting	-2	-0.926	-0.926	-0.844	-0.926	-0.844	-0.926	-0.844	0	0
	-0.926	-0.844	-0.844	-0.761	-0.844	-0.761	-0.844	-0.761	0	0
	-0.844	-0.761							0	0
CNC machining	-2	-0.926	-2.000	-0.926	-2.000	-0.926	-2.000	-0.926	0	0
	-0.926	-0.844	-0.926	-0.844	-0.926	-0.844	-0.926	-0.844	0	0
	-0.844	-0.761	-0.844	-0.761	-0.844	-0.761	-0.844	-0.761	0	0

Notes: p1: proportion of points for a given deviation range for "as built" test piece; p2: proportion of points for a given deviation range for post processed test piece; z_{α} : value for inverse normal distribution associated with the level of significance alpha

For all three materials, the shot peening technique applied progressively up to 8 minutes (Table II and Figure 16) produced a very good uniform distribution of ± 0.1 mm deviation range across relatively wide surfaces, leading to very good dimensional

accuracy for Nylon test piece where 82.6 per cent of the total number of points fell into the ± 0.1 mm deviation range (Figure 7). Up to 4 and 8 min, excellent dimensional accuracy rates of 92.1 per cent and 95.6 per cent were obtained for

Table V Deviation ranges with no difference in population for ABS test pieces

Post-processing techniques	Significance levels				% of observed no. of points			
	$\alpha = 0.002$ (99.8%), $Z_{\alpha/2} = 3.090$		$\alpha = 0.01$ (99%), $Z_{\alpha/2} = 2.575$		For "as-built" $p1 \times 100$	For the process $p2 \times 100$		
	Deviation ranges (mm)		Deviation ranges (mm)		Deviation ranges (mm)			
Tumbling	0.513	0.596	0.513	0.596	0.1	0		
	0.596	0.678	0.596	0.678	0.1	0		
	0.678	0.761	0.678	0.761	0.1	0		
	1.009	2	1.009	2.000	0.1	0.1		
Shot peening	-0.926	-0.844	-0.9261	-0.8435	-0.9261	-0.8435	0	0
Hand finishing	-2	-0.926	-2	-0.9261			0	0
Spray painting	-2	-0.926	-2	-0.9261			0	0
	-0.926	-0.844	-0.926	-0.844	-0.926	-0.844	0	0
	-0.844	-0.761	-0.844	-0.761	-0.844	-0.761	0	0
	-0.761	-0.678	-0.761	-0.678	-0.430	-0.348	0	0
	-0.596	-0.513	1.009	2.000			0	0
	-0.43	-0.348			-0.430	-0.348	0.1	0.1
	1.009	2				0.1	0.1	
CNC machining	-0.926	-0.844	-0.926	-0.844	-0.926	-0.844	0	0
	-0.844	-0.761	-0.844	-0.761	-0.844	-0.761	0	0
Chemical treatment	-2	-0.926					0	0
	-0.926	-0.844	-0.926	-0.844	-0.926	-0.844	0	0
	-0.844	-0.761					0	0

Notes: The value of $Z_{\alpha/2}$ is sourced from Montgomery and Runger (2011); p1: Proportion of points for "as-built" test piece; p2: Proportions of points for the post processed test piece

Figure 14 Progressively tumbled Nylon (a) and Alumide® test pieces

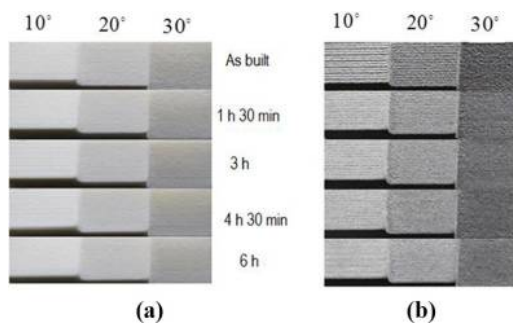

Alumide® and ABS test pieces respectively (Figures 8 and 9). However, shot peening is generally characterized by the wearing away of small protrusions and sharp corners and a possible concentration of shots into confine area such as corners as the process is manually conducted. For ABS test pieces, the shot peening delaminates the external layers of relatively wide surfaces. This is more pronounced on 10°, 20° and 30° surface inclination angles where the stair step effect is much more evidenced [Figure 16(c)].

With a generalized lack of consistency in a uniform distribution of deviation ranges even across individual surfaces [Figures 10(d), 11(d), 17(a) and 17(b)], within the ± 0.1 mm deviation range from the "as-built" test pieces, hand finishing performed for a total period of 5 hours and 20 minutes produced satisfactory dimensional accuracy for Nylon and Alumide® with 63.5 per cent and 69.2 per cent of the total

Figure 15 Problems associated with the tumbling of ABS test pieces

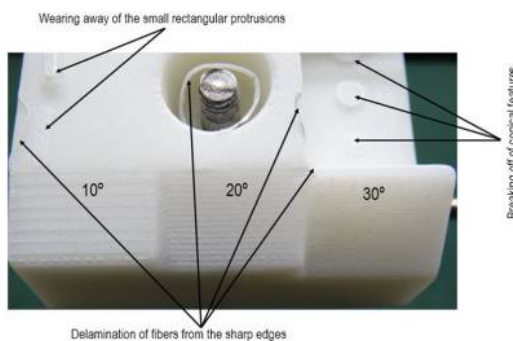

Figure 16 Progressively shot peened Nylon (a), Alumide® (b) and ABS test pieces (c)

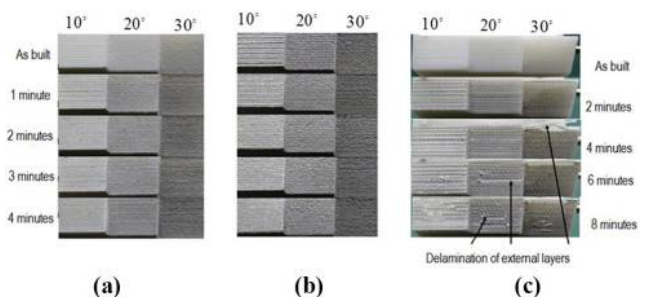
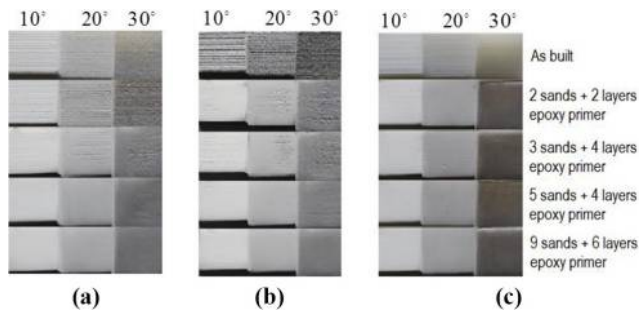
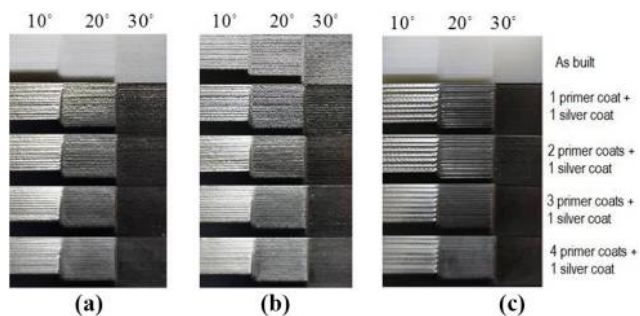
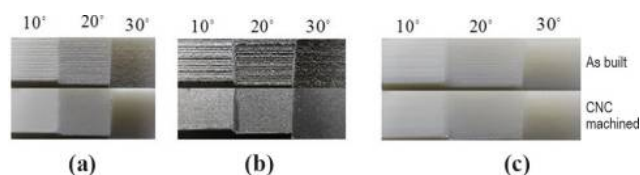

Figure 17 Progressively hand finished Nylon (a), Alumide® (b) and ABS (c) test pieces

number of touch probe scanned points on the surfaces of the Nylon and Alumide® test pieces respectively. For the ABS test pieces, [Figures 12(d) and 17(c)] despite the lack of consistency in a uniform distribution of the ± 0.1 mm deviation range, it can be stated that very good dimensional accuracy was achieved as the rate of points falling within the ± 0.1 mm deviation range was raised to 80 per cent.

Spray painting [Figures 10(e), 11(e), 12(e) and 18] was generally dominated by consistent and uniform distribution of significant positive deviation ranges across almost the entire test piece for all the three materials because of a build-up of paint on the surfaces. Within ± 0.1 mm deviation range poor dimensional accuracy was produced for Nylon (3 per cent), Alumide® (18.3 per cent) and for ABS (1.3 per cent).

CNC machining [Figures 10(f), 11(f), 12(f), and 19] showed a trend of producing negative deviation ranges close to the targeted ± 0.1 mm deviation range from the “as-built” test piece. These unexpected results indicate that excess material has been removed from the surfaces of the test pieces. The repeated error for the all three CNC machined test pieces may have been caused

Figure 18 Progressively spray painted Nylon (a), Alumide® (b) and ABS (c) test pieces**Figure 19** CNC machined Nylon (a), Alumide® (b) and ABS (c) test pieces

by improper setup or calibration during the setting of the cutting parameters of the machine in the vertical direction (Z-axis).

Garg et al. (2016) and Singh and Singh (2017) reported that with exposure time of 40 minutes, the treatment of ABS specimens with cold vapour of acetone produced acceptable surface finish ensuring consistent surfaces. However, the long exposure of 90 minutes under cold vapour led to geometrical change in losing features and rounding of sharp corners. Garg et al. (2017) observed that the improvement of surface finish of ABS parts using hot vapour of acetone produced aggressive chemical reactions and it was found difficult to control the damage of the part surface. In the present investigation, chemical treatment [Figures 12(g) and 20] consisting in dissolving the surfaces of the ABS test piece using acetone for a period of 60 seconds at room temperature was found to produce excellent uniform surface distribution of ± 0.1 mm from the deviation range from the geometry of the “as-built” test piece. Despite the presence of (-0.183 to -0.1) mm negative deviation range testifying to the shrinkage effect as observed by Galantucci et al. (2009), the features with small protrusions, round cavities, sharp edges and top surfaces of the conical features all retained excellent dimensional accuracy with a proportion of 90 per cent of the total number of touch probe scanned points on the ABS surfaces.

McCullough and Yadavalli (2013) realised that the removal of ABS material during an acetone bath caused pitting and subsequent deposition of ABS on the surface thus forming peaks. This effect is also observed in the current investigation where positive deviation ranges ($+0.1$ to $+0.348$) are displayed on the top horizontal surface of ABS chemically treated test piece [Figure 12(g)].

9. Conclusions

Although there is published work regarding the improvement of surface finishing of AM components using various post-processing techniques (Pandey et al., 2003; Schmid et al., 2009; Galantucci et al., 2009; Addanki et al., 2012; De Beer et al., 2012; Daneshmand and Aghanajafi, 2012; Kuo and Su, 2013; Azhar and Anoop, 2014; Raja, 2016), very little research has been done to investigate the detrimental effects of improving the surface roughness and its influence on the dimensional accuracy of AM parts. In this work, the Chi-square test (χ^2) and statistic Z-observed (Z_{obs}) test methods confirmed that there is a significant difference between the deviation range proportions when comparing the “as-built” part to any one of the six post processed parts. Within a ± 0.1 mm deviation range, spray painting was generally characterized by consistency in a uniform distribution of excessive positive deviations; and with hand finishing being dominated by inconsistency in deviation ranges. Despite the rounding of sharp corners and the removal of small protrusions, the dimensional accuracy of relatively wide surfaces of nylon or

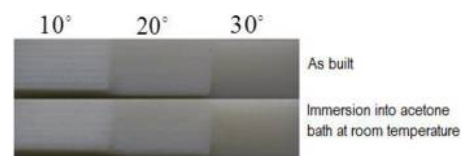
Figure 20 Chemically treated ABS test pieces into acetone bath

Alumide[®] test pieces was not significantly affected by the tumbling or shot peening processes. The immersion of ABS test pieces into an acetone bath produced the best dimensional accuracy. Improvement of surface finish of relatively wide surfaces of the test pieces through CNC machining influenced the dimensional accuracy of the test piece surfaces negatively, mainly due to an error in setting and calibration of the cutting parameters in Z-direction on the CNC machine. This error could have been prevented by setting individual calibration and cutting parameters for each angled surface, but this would have increased the cost of machining to an unacceptable level. Tumbling or shot peening should not be used for improving the surface finish of FDM ABS parts as the dimensional accuracy of the part is negatively affected by the two techniques that are deemed too harsh. In conclusion, service bureaus that produce prototypes and end use functional parts through AM are recommended to apply the findings of this investigation to real world projects.

10. Future work

The preliminary statistical data obtained from the touch probe scanning technique were generalized to the entire test piece and are not specific to an individual surface inclination angle. Future work should concentrate on acquiring the dimensional deviation ranges based on each angled surface to establish the effect of surface inclination angle on shrinkage of the “as-built” part and to identify if there is any correlation between the dimensional accuracy and the surface finish of each post-processing technique. To establish the degree of repeatability of results, future research could focus on shot peening and tumbling process parameters that influence the surface finish and dimensional accuracy of the parts. The effect of post-processing techniques on mechanical properties of tumbled and shot peened nylon and Alumide[®] and chemically treated ABS parts is also of interest for future study.

References

- Addanki, S.R., Medha, A.D., Venkatesh, J.V.L. and Deepesh, O. (2012), “Investigation of post processing techniques to reduce the surface roughness of fused deposition modelled parts”, *International Journal of Mechanical Engineering and Technology (IJMET)*, Vol. 3 No. 3, pp. 531-544.
- Akande, O.S. (2015), “Dimension accuracy and surface finish optimization of fused deposition modelling parts using desirability function analysis”, *International Journal of Engineering Research & Technology (IJERT)*, Vol. 4 No. 4, pp. 196-202.
- Anoop, K.S., Ohdar, R.K. and Mahapatra, S.S. (2009), “Improving dimensional accuracy of fused deposition modelling part using taguchi method”, *Material and Design*, Vol. 30, pp. 4243-4252.
- Anoop, K.S., Vedansh, C., Saurav, D. and Siba, S.M. (2011), “Optimization of process parameters in fused deposition modeling using weighted principal component analysis”, *Journal of Advanced Manufacturing Systems*, Vol. 10 No. 2, pp. 241-259.
- Azhar, E. and Anoop, K.S. (2014), “Metallization of FDM parts using the chemical deposition technique”, *Coatings*, Vol. 4, pp. 574-586.
- Bual, G.S. and Kumar, P. (2014), “Method to improve surface finish of parts produced by fused deposition modelling”, *Manufacturing Science and Technology*, Vol. 2 No. 3, pp. 51-55.
- Daneshmand, S. and Aghanajafi, C. (2012), “Description and modelling of additive manufacturing technology for aerodynamic coefficient measurement”, *Strojnicki Vestnik – Journal of Mechanical Engineering*, Vol. 58 No. 2, pp. 125-133.
- Daneshmand, S., Aghanajafi, C. and Shahverdi, H. (2013), “Investigation of rapid manufacturing technology effect on aerodynamics properties”, *Tehnicki Vjesnik*, Vol. 20 No. 3, pp. 425-433.
- De Beer, N. (2013), *Additive Manufacturing – Turning Mind into Matter-Industry Evaluation and Recommendations Report*, Center for Applied Competitiveness Technologies (CACT), Sierra College, CA.
- De Beer, D.J., Becker, L., Van del Walt, P., Mauchline, D., Campbell, R.I. and Dean, L.T. (2012), “Additive manufacturing of alumide jewellery”, *Proceedings of 13th Annual RAPDASA Conference in Pretoria, South Africa*, p. 11.
- Dzullijah, I., Songlin, D. and Shoujin, S. (2014), “Roughness prediction for FDM produced surfaces”, *International Conference Recent Trends in Engineering & Technology (ICRET) in Batan, Indonesia*, pp. 13-14.
- EOS GmbH (2005), “Operation PSW 3.2-EOSINT P385 laser-sintering system for plastics-operation”, *Electro Optical Systems*, Article number: 9215-0111, Edition: 10.05.
- Galantucci, L.M., Lavecchia, F. and Percoco, G. (2009), “Experimental study aiming to enhance the surface finish of fused deposition modelled parts”, *CIRP Annals-Manufacturing Technology*, Vol. 58 No. 1, pp. 189-192.
- Galantucci, L.M., Bodi, I., Kacani, J. and Lavecchia, F. (2015), “Analysis of dimensional performance for 3D open-source printer based on fused deposition modelling technique”, *Procedia CIRP*, Vol. 28, pp. 82-87.
- Garg, A., Bhattacharya, A. and Batish, A. (2016), “On surface finish and dimensional accuracy of FDM parts after cold vapor treatment”, *Materials and Manufacturing Process*, Vol. 31 No. 4, pp. 522-529.
- Garg, A., Bhattacharya, A. and Batish, A. (2017), “Chemical vapor treatment of ABS parts built by FDM: analysis of surface finish and mechanical strength”, *The International Journal of Advanced Manufacturing Technology*, Vol. 89 Nos 5/8, pp. 2175-2191.
- Goodridge, R.D., Tuck, C.J. and Hague, R.J.M. (2012), “Laser sintering of polyamides and other polymers”, *Progress in Materials Science*, Vol. 57 No. 2, pp. 229-267.
- Kitsakis, K., Alabey, P., Kechagias, N. and Vexevanidis, N. (2016), “A study of dimensional accuracy obtained by low cost 3D printing for possible application in medicine”, *20th Innovation Manufacturing Engineering and Energy conference (IManEE 2016)*, *IOP Conf. series: Materials Science and Engineering*, Vol. 161, pp. 1-6.
- Krolczyk, G., Raos, P. and Legutko, S. (2014), “Experimental analysis of surface roughness and surface texture of machined and fused deposition modelled parts”, *Tehnicki Vjesnik*, Vol. 21 No. 1, pp. 217-221.
- Kruth, J.P., Levy, G., Schinder, R., Craeghs, T. and Yasa, E. (2008), “Consolidation of polymers by selective laser sintering”, [s.l.], available at: <https://core.ac.uk/download/pdf/34402296.pdf> (accessed 28 November 2018).

- Kuo, C.C. and Su, S.J. (2013), "A simple method for improving surface quality of rapid prototype", *Indian Journal of Engineering Sciences*, Vol. 20, pp. 465-470.
- Latiff, Z.A., Rahman, M.R.A. and Saad, F. (2013), "Dimensional accuracy evaluation of rapid prototyping fused deposition modelling process of FDM200mc machine on basic engineering profile", *Applied Mechanics and Materials (AMM)*, Vol. 465, pp. 96-100.
- Lieneke, T., Denzer, V., Adam, G.A.O. and Zimmer, D. (2016), "Dimensional tolerances for additive manufacturing: experimental investigation for fused deposit modelling", *14th CIRP conference on Computer Aided Tolerancing (CAT), Procedia CIRP*, Vol. 43, pp. 286-291.
- McCullough, E.J. and Yadavalli, V.K. (2013), "Surface modification of fused deposition modelling ABS to enable rapid prototyping of biomedical microdevices", *Journal of Materials Processing Technology*, Vol. 213 No. 6, pp. 947-954.
- Manfredi, D., Calignano, F., Krishnan, M., Canali, R., Ambrosio, E.P., Biamino, S., Urgues, D., Pavese, M. and Fino, P. (2014), "Additive manufacturing of Al alloys and aluminium matrix composites (AMCs)", *INTECH Open Science/Open Minds*.
- Mireles, J., Adame, A., Espalin, D., Medina, F., Winker, R., Hoppe, T., Zinniel, B. and Wicker, R. (2011), "Analysis of sealing methods for FDM fabricated parts", *Couri Symposium*, Reviewed 17 August 2011, pp. 185-196.
- Montgomery, D.C. and Runger, G.C. (2011), *Applied Statistics and Probability for Engineers*, 5th ed., John Wiley & Sons, Hoboken, NJ.
- Nancharaiyah, T., Ranga, R. and Ramachandra, V.R. (2010), "An experimental investigation on surface quality and dimensional accuracy of FDM components", *International Journal of Emerging Technologies*, Vol. 1 No. 2, pp. 106-111.
- Noriega, A., Blanco, D., Alvarez, B.J. and Garcia, A. (2013), "Dimensional accuracy improvement of FDM square cross-section parts using artificial neural networks and optimization algorithm", *The International Journal of Advanced Manufacturing Technology*, Vol. 69 Nos 9/12, pp. 2301-2313.
- Pandey, P.M., Reddy, N.V. and Dhande, S.G. (2003), "Improvement of surface finish by staircase machining in fused deposition modelling", *Journal of Material Processing Technology*, Vol. 132 Nos 1/3, pp. 323-331.
- Pham, D.T., Dotchev, K.D. and Yusoff, W.A.Y. (2008), "Deterioration of polyamide powder properties in laser sintering process", *Journal of Mechanical Engineering Science*, Vol. 222 No. 11, pp. 2163-2176.
- Raghunath, N. and Pandey, M.P. (2007), "Improving accuracy through shrinkage modelling by using Taguchi method in selective laser sintering", *International Journal of Machine Tools & Manufacture*, Vol. 47, pp. 985-995.
- Raja, K. (2016), "A review on chemical processes for plastics substrates used in engineering industries", *International Journal of ChemTech Research*, Vol. 9 No. 7, pp. 354-365.
- Schmid, M., Simon, C. and Levy, G.N. (2009), "Finishing of SLS-parts for rapid manufacturing (RM)-a comprehensive approach", *INSPIRE*, pp. 1-10.
- Shirazi, S.F.S., Gharekhani, S., Mehrali, M., Yarmand, H., Metsalaar, H.S.C., Kadri, N.A. and Osman, N.A.A. (2015), "A review on powder-based additive manufacturing for tissue engineering: selective laser sintering and inkjet 3D printing", *Science and Technology of Advanced Materials*, Vol. 16, pp. 1-20.
- Shrivastava, V., Parida, S.K. and Pandey, P.M. (2010), "Surface roughness studies in selective laser sintering of glass filled polyamide", *Proceedings of 36th International MATADOR Conference, Manchester*.
- Singh, R. (2013), "Some investigations for small-sized product fabrications with FDM for plastic components", *Rapid Prototyping Journal*, Vol. 19 No. 1, pp. 58-63.
- Singh, R. and Singh, H. (2017), "Investigations for improving the surface finish of FDM based ABS replicas by chemical vapor smoothing process: a case study", *Assembly Automation*, Vol. 37 No. 1, pp. 13-21.
- Tanay, V.D., Prashant, M.K., Gaurav, C.N. and Vishal, N.B. (2013), "Multi objective optimization of built orientation for rapid prototyping of connecting rod", *International Journal of Scientific Research and Management*, Vol. 1 No. 1, pp. 13-18.
- Urednik (2013), "Alumide®-polyamide carbon fiber-reinforced", available at: www.3dimpuls.com (accessed 21 July 2014).
- Zarringhalam, H., Hopkinson, N., Kamperman, N.F. and de Vlioger, J.J. (2006), "Effect of processing on microstructure and properties of SLS nylon 12", *Material Science and Engineering*, Vols 435/436, pp. 172-180.

About the authors

Joseph Nsengimana obtained MSc in 1996 at Kharkov State Polytechnic University (Ukraine). He obtained MTech in 2016 at Central University of Technology, Free State (CUT), South Africa. Since 2001, Nsengimana held positions of Assistant Lecturer and Lecturer at University of Rwanda – College of Science and Technology. Currently, Nsengimana is a Lecturer and a Doctor of Engineering: Mechanical student at CUT in Mechanical and Mechatronics Engineering Department. Joseph Nsengimana is the corresponding author and can be contacted at: jnsengimana@cut.ac.za

Dr Jacobus Van der Walt obtained DTech from CUT, Mechanical and Mechatronics Engineering Department. Currently, Dr Van der Walt is a Senior Researcher in Mechanical and Mechatronics Engineering Department, CUT.

Dr Eujin Pei obtained BA (Hons) in Product Design from Central Saint Martins College of Art and Design (University of the Arts London), and MSc and PhD in Industrial Design from Loughborough University. He was a Senior Lecturer in Product and Furniture Design at De Montfort University from 2010 to 2014. Dr Pei is the Programme Director for both BSc Product Design and BSc Product Design Engineering at Brunel University, London.

Maruf Miah graduated from De Montfort University (DMU). He worked as Product Designer at DMU.

For instructions on how to order reprints of this article, please visit our website:

www.emeraldgroupublishing.com/licensing/reprints.htm

Or contact us for further details: permissions@emeraldinsight.com