

Coordination control of robot manipulators using flat outputs



Elisha D. Markus^{a,*}, Hamam Yskander^b, John T. Agee^b, Adisa A. Jimoh^b

^a Department of Electrical, Electronic and Computer Systems, Central University of Technology Free State, South Africa

^b Department of Electrical Engineering, Tshwane University of Technology Pretoria, South Africa

HIGHLIGHTS

- Flatness based coordination of multiple interconnected flexible robots presented.
- Constraints of coupling dynamics are taken into account in the synchronization design.
- Flexibility in the choice of synchronization parameters.
- Synchronization of multiple robots is enhanced via trajectory design based on flatness.

ARTICLE INFO

Article history:

Received 19 March 2015
 Received in revised form
 24 April 2016
 Accepted 13 May 2016
 Available online 21 May 2016

Keywords:

Differential flatness
 Synchronizing control
 Flat output
 Flexible robot
 Robot formation

ABSTRACT

This paper focuses on the synchronizing control of multiple interconnected flexible robotic manipulators using differential flatness theory. The flatness theory has the advantage of simplifying trajectory tracking tasks of complex mechanical systems. Using this theory, we propose a new synchronization scheme whereby a formation of flatness based systems can be stabilized using their respective flat outputs. Using the flat outputs, we eliminate the need for cross coupling laws and communication protocols associated with such formations. The problem of robot coordination is reduced to synchronizing the flat outputs between the respective robot manipulators. Furthermore, the selection of the flat output used for the synchronizing control is not restricted as any system variable can be used. The problem of unmeasured states used in the control is also solved by reconstructing the missing states using flatness based interpolation. The proposed control law is less computationally intensive when compared to earlier reported work as integration of the differential equations is not required. Simulations using a formation of single link flexible joint robots are used to validate the proposed synchronizing control.

© 2016 Elsevier B.V. All rights reserved.

1. Introduction

The problem of robot coordination and cooperation has been studied by researchers over the years [1–9]. The coordination control problem involves synchronization of a formation of robot manipulators in a specific task. It may be required for a swarm of robotic manipulators to cooperate towards accomplishing a given mission in form of a common predefined trajectory. There are many areas where single robots are limited in terms of manipulability, flexibility, reachability and maneuverability [10]. In such instances, cooperative robots are deployed to execute the job. Such cooperative multi-robot behavior results in increased efficiency and reduced turn around times in industrial processes. Reliability is also improved when multi-robot systems are put

in parallel redundant formations. Robot cooperation has been a major area of application in space applications [11–13], confined spaces like in the mines [14–16], assessing hazardous areas [17,18], power systems like the overhead Transmission Line Inspection Equipment [19,20] and in production lines [21].

This work is motivated by recent results in the area of robot coordination. For instance in [21,22] a synchronized tracking control was developed for the multi-robotic manipulator systems (MRMS) in the presence of uncertain dynamics. The authors also applied neural network to enhance synchronization of the MRMS. Kris in [11] presented a nonlinear control solution for spacecraft formations indicating the stability of their controllers. Chiddarwar [23] used multi-agent theory to motion planning of coordinated multiple robots. Every participating robot in the coordinated task is considered as an agent. The method allows for the design of optimal trajectories in the presence of dynamic and kinematic constraints. In [24], a new concurrent synchronization scheme for Lagrangian dynamics was proposed. It

* Corresponding author. Tel.: +27 515073514.
 E-mail address: emarkus@cut.ac.za (E.D. Markus).

is a decentralized control strategy where adaptive synchronization and partial state coupling is used. Other works by Lee [25], showed that feedback linearization may be employed to achieve consensus in nonlinear systems. Further work done by Bidram [26], presented a heterogeneous multi agent cooperative formation synchronized using feedback linearization. This approach led to a higher order synchronization problem which is effectively controlled using a microgrid as a test bed. While most of these studies are recent, they often require cross coupling within the network topology and resolution of communication protocols to achieve coherent coordination. The structure of these systems can be relatively complex and computationally expensive.

In this paper, the control problem is formulated as follows: it is desired to design a feed-forward and feedback control that synchronizes two or more robots working together. It is assumed that only one measured parameter is available to the lead robot. The remaining control parameters such as velocities and acceleration need to be reconstructed. The other robots in the network will have to synchronize their control variables when interconnected to the leading robot. The network of robots may be of similar or different dynamics. It is assumed that all the robots in the formation are differentially flat hence each of the robots can be characterized in terms of their respective flat outputs. The flat output is a fictitious parameter that always has a physical meaning. The flatness-based cooperative control depends on the flat outputs and their derivatives up to a certain order and not on the system state variables.

The benefits of using the flat outputs as synchronization parameters are numerous; the nonlinear system is well characterized by its flat output and defines the system behavior globally as opposed to using just any state parameter. The flat output can be freely chosen thereby providing a flexibility in design of the controller and liberty to synchronize heterogeneous robot formations. Unmeasured parameters can be easily estimated in the control problem. Lastly, motion planning which is a major benefit of using differential flatness is effortlessly solved in the coordination schemes.

The main aim of this paper is to study the synchronization of cooperating robots where the flatness of the robots has been established to show that any system parameter such as system states or inputs can be freely selected as the synchronizing parameter. This is made possible by the flat output which is a fictitious parameter that can be freely chosen. This contributes to the problem of cooperation of robot manipulators.

The coordination control problem is posed using two or more flexible robot manipulators. Flexible robots are employed in situations where speed, dexterity and compliance are required. Cooperation of flexible manipulators with effective vibration control systems will be more beneficial when compared to single robots in terms of their low mass of moving parts, extended reach and increased accuracy, reduced cost and power consumption.

It is assumed that at least one robot parameter can be measured. The other unmeasured parameters can be estimated using flatness based reconstructors (see [27–29]). In this work, the concept of flat coupling in the interconnections is proposed whereby only the flat outputs are used to connect the systems together. The proposed synchronization controller based on differential flatness is quite attractive since velocity and acceleration sensors will not be required thereby reducing the cost of the controller. A similar work in literature is that of Levine [30] where synchronization was carried out for a pair of independent windshield wipers. In this paper, clock control was used to achieve synchronization for torque limited motors in a leader–follower formation.

The rest of the paper is hereby presented: the model of the cooperative robot formation is presented in Section 2. Differential flatness is revised in Section 3. The proposed controller is presented in Section 4. Simulations and results obtained are illustrated in Section 5. The concluding remarks are recorded in Section 6.

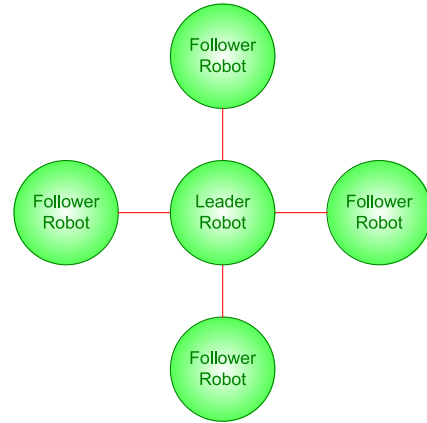

Fig. 1. Model of robot formation.

2. Modeling the cooperative system

The robot cooperative system can be modeled as a set of homogeneous or heterogeneous formation. Once the flatness property of each robot is established, synchronization can take place for the task at hand. The formation has a leader robot with dynamics $f(q_L, \dot{q}_L, \ddot{q}_L)$ where q_L is the generalized coordinate of the leader robot. For this study we consider a single link robot with joint flexibility to illustrate our proposed control. The flexible manipulator arm has been described in our earlier studies [31]. We also assume that the cooperative robots formation is similar in dynamics. However to differentiate between them, different physical parameters such as inertia and mass values for the links can be used. Joint flexibility magnifies the control problem since we have to account for link deflections which are unactuated and difficult to track. This is more so as the model of the flexible robot arm is oriented vertically which introduces gravity in the spring. This means that any torque on the motor will result in displacements both at the motor and in the link deflection.

Fig. 1 shows a schematic of the robot formation. The formation represents a leader robot and follower robots. The leading robot provides the reference trajectory to be synchronized by the other follower robots. If we are able to plan the motion for the lead robot and the respective follower robots are able to track this lead motion, then the coordination problem is said to be resolved. The synchronization of all the motions of the multi robotic system can be seen as a form of cooperation or coordination of the system. Hence synchronization, coordination, and cooperation will be used interchangeably to describe similar behavior of the robot formation. In this study, we will consider two similar cooperating robots. One is the robot leader denoted in the dynamic equations as L and the other a follower F . The dynamics of the leader and follower robots are given by [31]:

$$\begin{aligned} J_{Li}(\ddot{\theta}_i + \ddot{\alpha}_i) + K_{si}\alpha_i - m_i g h_i \sin(\theta_i + \alpha_i) &= 0 \\ (J_{Li} + J_{hi})\ddot{\theta}_i + J_{Li}\ddot{\alpha}_i - m_i g h_i \sin(\theta_i + \alpha_i) &= \tau_i - B_i \dot{\theta}_i \\ y &= \theta_i + \alpha_i \quad i = L, F \end{aligned} \quad (1)$$

L and F signify the leader and follower robots. θ and α are the motor angle and link deflections respectively. J_L , K_s , m , g , h , J_h and B_i are constant physical parameters that are known. The Torque of the motor is driven by the voltage applied to the armature V . The relationship between Torque and the applied voltage is:

$$\tau = \frac{K_m K_g}{R_m} V - \frac{K_m^2 K_g^2}{R_m} \dot{\theta} \quad (2)$$

where $\dot{\theta} = w$, $i = \frac{\tau}{K_g K_m}$ and $V = i R_m + K_m K_g w$.

Henceforth, the voltage V applied to the armature will be used as our control variable for the flexible robot.

3. Differential flatness analysis

We refer to earlier work by the authors on the Flexible robot where the flat output was determined as the motor angle $y = \theta$ [31]. This is a case of underactuation where 1 DOF of the robot is not accounted for. In the case where both motor angle and link deflection are measured, the tip position $(\theta + \alpha)$ of the robot can be taken as the flat output. Note that here the robot is fully actuated since the values of the motor position and link deflection are known. And finally in the case where only the link deflection α is measured can be taken as the flat output under some special conditions. Let us assume that from Eq. (1), the constant parameters such as $J_L = J_F$, $M_L = M_F$ are given. Then only the measured parameters vary for the respective robots. We also assume that servo damping $B_i = 0$ as this has negligible effect on the robot dynamics. As mentioned earlier, the differential flatness property implies that the system states and inputs may be completely recovered from the flat output without integrating any differential equations. This is of immense benefit to solving the problem of motion planning as well as stabilizing reference trajectories [32–35]. We now consider two main scenarios:

Case 1. Tip position fully measured for leader robot

From earlier work [31], we have shown that the flexible manipulator oriented vertically is fully static feedback linearizable hence differentially flat. Here we choose the flat output as the tip position of the manipulator.

$$y_L = \theta_L + \alpha_L. \quad (3)$$

The transformation between the flat output and the robot states may be derived (for clarity, we define: $(\theta, \dot{\theta}, \alpha, \dot{\alpha})$ as (x_1, x_2, x_3, x_4)):

$$\begin{aligned} y &= x_1 + x_3 \\ \dot{y} &= x_2 + x_4 \\ \ddot{y} &= -\frac{K_S}{J_L}x_3 + \frac{mgh \sin(x_1 + x_3)}{J_L} \\ y^{(3)} &= \left(-\frac{K_S}{J_L} + \frac{mgh \cos(x_1 + x_3)}{J_L}\right)x_4 + \frac{mgh \cos(x_1 + x_3)}{J_L}x_2. \end{aligned} \quad (4)$$

And the states may be written in terms of the flat output as:

$$\begin{aligned} x &= \alpha_0(y, \dot{y}, \ddot{y}, y^{(3)}) \\ u &= \alpha_1(y, \dot{y}, \ddot{y}, y^{(3)}, y^{(4)}). \end{aligned} \quad (5)$$

Expanding Eq. (5)

$$\begin{aligned} x_1 &= y + \frac{-mgh \sin(y) + J_L \ddot{y}}{K_S} \\ x_2 &= \dot{y} - \frac{-\dot{y}mgh \cos(y) + J_L y^{(3)}}{K_S} \\ x_3 &= \frac{mgh \sin(y) - J_L \ddot{y}}{K_S} \\ x_4 &= \frac{\dot{y}mgh \cos(y) - J_L y^{(3)}}{K_S}. \end{aligned} \quad (6)$$

Using the flatness theory, the control law for the fully measured tip position of the leader robot is given as:

$$u = \beta^{-1}(y)[v(y, \dot{y}, \ddot{y}, y^{(3)}, y^{(4)}) - \alpha(y, \dot{y}, \ddot{y}, y^{(3)}, y^{(4)})]. \quad (7)$$

This shows a complete diffeomorphism with no zero dynamics.

This expression (in states and control) shows that the robot is fully linearized and decoupled by static feedback where v is the virtual input that is designed using the Hurwitz criterion. Using the

input transformation, the robot can be steered from point to point as required. The control designed to do this is given in Eq. (8).

$$\begin{aligned} u &= \frac{1}{K_S \zeta_1} (v J_h \zeta_3 + \sin(y) \dot{y}^2 \zeta_2 J_h - \zeta_1^2 \dot{y} m g h \cos(y) \\ &\quad - K_S \zeta_2 \sin(y) + K_S \dot{y} \zeta_3 + \zeta_1^2 \dot{y} K_S + \zeta_1^2 y^{(3)} J_L \\ &\quad + K_S R_m J_h \ddot{y} - \cos(y) \zeta_2 J_h \dot{y}) \end{aligned} \quad (8)$$

where $\zeta_1 = K_m^2 K_g^2$, $\zeta_2 = m g h R_m$, $\zeta_3 = J_L R_m$.

The linear control is hereby given as $y^{(4)} = v$. Assume that the tip position measurement of the leader robot is available, then we can define a reference trajectory $y^*(t)$ for the flat output such that:

$$\begin{aligned} e &= y(t) - y^*(t) \\ \dot{e} &= \dot{y}(t) - \dot{y}^*(t) \\ \ddot{e} &= \ddot{y}(t) - \ddot{y}^*(t). \end{aligned} \quad (9)$$

The controller then tracks this trajectory in closed loop. The linearizing feedback control is hence:

$$\begin{aligned} v &= y^{*(4)} - K_3(y^{(3)} - y^{*(3)}) - K_2(\ddot{y} - \ddot{y}^*) - K_1(\dot{y} - \dot{y}^*) \\ &\quad - K_0(y - y^*). \end{aligned} \quad (10)$$

If we set Eq. (10) as a reference $v^* = y^{*(4)}$, then for an additional disturbance $d(t)$, the equation becomes:

$$e^{(4)} = v - v^* + d(t). \quad (11)$$

We design the control such that as $t \rightarrow \infty$ the error e converges to zero in the presence of the disturbance. The gains $K_i = 0, 1, 2, 3$ are chosen so that the polynomials

$$s^4 + K_3 s^3 + K_2 s^2 + K_1 s + K_0 = 0 \quad (12)$$

have their roots in the negative plane.

Case 2. Tip position partially measured for follower robot

We now design a controller for the case where only the motor position is measured. Hence we refer to θ as the flat output. The parameter α and higher derivatives have to be estimated for the control law design. We assume that for the follower robot, only the motor angle measurement is available. The flat output is proposed as:

$$y_F = \theta. \quad (13)$$

We can now estimate the value of α based on the flat output as:

$$\alpha_e = \frac{J_h}{K_S} \left(\ddot{\theta} + \frac{K_m^2 K_g^2 \dot{\theta}}{R_m J_h} \right). \quad (14)$$

Hence the tip position of the robot and derivatives in terms of the flat output and derivatives (if link deflections were considered) are given as:

$$\begin{aligned} y_F &= \theta + \frac{J_h}{K_S} \left(\ddot{\theta} + \frac{K_m^2 K_g^2 \dot{\theta}}{R_m J_h} \right) \\ \dot{y}_F &= \dot{\theta} + \frac{J_h}{K_S} \left(\dot{\theta}^{(3)} + \frac{K_m^2 K_g^2 \ddot{\theta}}{R_m J_h} \right) \\ \ddot{y}_F &= \ddot{\theta} + \frac{J_h}{K_S} \left(\theta^{(4)} + \frac{K_m^2 K_g^2 \theta^{(3)}}{R_m J_h} \right). \end{aligned} \quad (15)$$

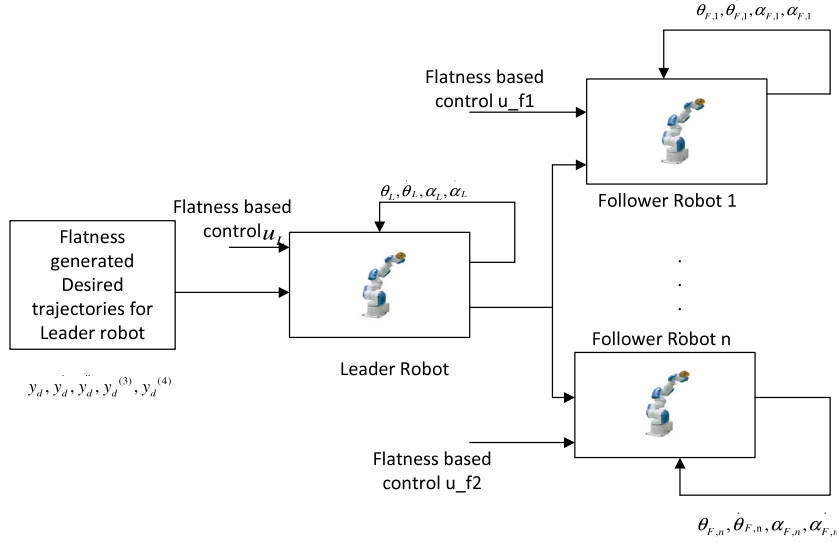

Fig. 2. Model of leader–follower robot formation.

Using the same concept as in case 1, the equations for the states in terms of the flat output of Eq. (13) are given by:

$$\begin{aligned} x_1 &= y_F \\ x_2 &= \dot{y}_F \\ x_3 &= \frac{J_h}{K_S} \left(\ddot{y}_F + \frac{K_m^2 K_g^2 \dot{y}_F}{R_m J_h} \right) \\ x_4 &= \frac{J_h}{K_S} \left(y_F^{(3)} + \frac{K_m^2 K_g^2 \ddot{y}_F}{R_m J_h} \right). \end{aligned} \quad (16)$$

And the control input is given by:

$$u = \beta^{-1}(x) [v - \alpha(y)] \quad (17)$$

where

$$\begin{aligned} \alpha(y) &= \alpha_1 + \alpha_2 \dot{y}(t) + \alpha_3 \ddot{y}(t) + \alpha_4 y^{(3)}(t) \\ \alpha_1 &= \frac{mgh}{J J_h} \sin \left(y + \frac{K_m^2 K_g^2 \dot{y} + \ddot{y} R_m J_h}{R_m K_S} \right) \\ \alpha_2 &= -\frac{K_S K_m^2 K_g^2}{R_m J J_h} \\ \alpha_3 &= -\frac{K_S}{J_h} - \frac{K_S}{J_i} \\ \alpha_4 &= -\frac{K_m^2 K_g^2}{R_m J_h} \end{aligned} \quad (18)$$

and

$$\beta(x) = \frac{K_m^5 K_g^5}{R_m^3 J_h^3} - \frac{K_m K_g K_S}{R_m J_h^2}. \quad (19)$$

4. Synchronizing control design using flat outputs

Fig. 2 shows a typical leader–follower robot formation. Based on the statement of synchronization problem as defined by [36], mutual synchronization is said to take place when the angular position and velocity of all the robots $y_i, \dot{y}_i, i = 1, \dots, p$, coincide for any instant of time and simultaneously coincide with a common desired trajectory y^*, \dot{y}^* . The synchronous indices were proposed as:

$$J_i(y_i(t), \dot{y}_i(t)) = [y_i(t)^T, \dot{y}_i^T(t)].$$

The synchronizing function is hereby given by:

$$\begin{aligned} f_s(y_i, \dot{y}_i, y_j, \dot{y}_j)_{i,j} &= \|J_i(y_i, \dot{y}_i) - J_j(y_j, \dot{y}_j)\| \\ i, j &= 1, \dots, p, j \neq i \\ f_s(y_i, \dot{y}_i, y_j, \dot{y}_j)_{i,i} &= \|J_i(y_i, \dot{y}_i) - J_d(y_d, \dot{y}_d)\| \quad i = 1, \dots, p. \end{aligned} \quad (20)$$

The synchronous error for the i th robot is given by:

$$\begin{aligned} e_{si} &= y_i - y_i^* \\ \dot{e}_{si} &= \dot{y}_i - \dot{y}_i^*. \end{aligned} \quad (21)$$

For synchronous motion between the robots, the reference signals are defined as:

$$y_i^* = y^* - \sum_{j=1, j \neq i}^p K_{cp-i,j} (y_i - y_j) \quad (17)$$

$$\dot{y}_i^* = \dot{y}^* - \sum_{j=1, j \neq i}^p K_{cv-i,j} (\dot{y}_i - \dot{y}_j) \quad (18)$$

$$\ddot{y}_i^* = \ddot{y}^* - \sum_{j=1, j \neq i}^p K_{ca-i,j} (\ddot{y}_i - \ddot{y}_j).$$

$K_{cp-i,j}, K_{cv-i,j}, K_{ca-i,j}, i, j = 1, \dots, p$ are positive semidefinite diagonal matrices defining the interactions at position, velocity and acceleration between the robot formation.

From Eq. (8) the control for the leader robot is established. We also showed that the flat output may be parameterized using linear polynomial equations of certain order to accommodate the constraints [31]. We have already shown how easy it is to recover the remaining states and control inputs. With only the flat outputs available for the synchronizing control, we now design a synchronizing control for the follower robot based on reference trajectories from the leader robot. The main goal of the synchronizing control is to ensure that the flat outputs for the leader and follower robots coincide for all values of time. In other words,

$$y_L(t) - y_F(t) = 0 \quad \forall t \geq 0 \quad (22)$$

or

$$e_s = y_L(t) - y_F(t). \quad (23)$$

Eq. (23) is referred to as the synchronization error. The synchronization control is proposed as:

$$y_F^{(4)} = v(t). \quad (24)$$

The new control law is given by

$$v(t) = y_L^{*(4)} - K_3 e^{(3)} - K_2 \dot{e} - K_1 \dot{e} - K_0 e. \quad (25)$$

The synchronization error easily converges to zero with appropriate choice of the control gains.

The velocity and acceleration terms can be estimated easily using linear algebra without any need to integrate the state equations. Other methods exist for estimating the velocity terms of the controller like the higher order differential system (HODS), using model based observers, numerical differentiation, etc. Flies et al. have developed noise free method of estimating these variables by a method of numerical differentiation by integration [28,37,38]. This is well suited for practical implementation. In this paper, the differential terms will be estimated by means of polynomial interpolation.

The synchronization tracking errors from Eq. (25) are hereby defined by:

$$\begin{aligned} e &= y_F - y_L^* \\ \dot{e} &= \dot{y}_F - \dot{y}_L^* \\ \ddot{e} &= \ddot{y}_F - \ddot{y}_L^* \\ e^{(3)} &= y_F^{(3)} - y_L^{*(3)}. \end{aligned}$$

4.1. Open loop synchronization by motion planning

Using reference trajectories of the flat output, we carry out motion planning and synchronization in open loop. Hence we find a trajectory $t \mapsto y(t)$, defining $t \mapsto (x(t), u(t))$ for $t \in [t_i, t_f]$ that satisfies the flexible robot's equations. Fig. 3 shows the open loop synchronization model. Generally the trajectories can be expressed as:

$$t \mapsto \begin{pmatrix} x(t) \\ u(t) \end{pmatrix} = \begin{pmatrix} \phi_0(y(t), \dot{y}(t), \ddot{y}(t), \dots, y^{(q)}(t)) \\ \phi_1(y(t), \dot{y}(t), \ddot{y}(t), \dots, y^{(q+1)}(t)) \end{pmatrix}. \quad (26)$$

We therefore propose a reference trajectory for the synchronous tracking of the multirobot system as:

$$t \mapsto \begin{pmatrix} x(t) \\ u(t) \end{pmatrix} = \begin{pmatrix} \phi_0(y(t), \dot{y}(t), \ddot{y}(t), y^{(3)}(t)) \\ \phi_1 y^{(4)}(t) \end{pmatrix} \quad (27)$$

where $u(t)$ is given by Eq. (24). Assume that the model is exact and no external disturbances exist, we can easily steer the coordinated control in open loop. The time evolution of the trajectories is governed by the 4th order dynamics of the leader robot. If we know a priori the values of the variable $y(t_1), \dot{y}(t_1), \dots, y^{(n)}(t_1)$, and its derivatives at some point $t = t_1$ and the values of the variable $y(t_2), \dot{y}(t_2), \dots, y^{(n)}(t_2)$, and its derivatives at some point $t = t_2$, then we can solve the motion problem for the synchronous control for the trajectories of $y(t)$ for $t \in [t_1, t_2]$.

Using the flat outputs and their estimated derivatives up to order $(q + 1)$ we now steer the follower robot with the open loop input control of Eq. (28):

$$\begin{aligned} u_L &= \frac{1}{K_s \zeta_1} (y^{(4)} J h \zeta_3 + \sin(y) \dot{y}^2 \zeta_2 J h - \zeta_1^2 \dot{y} m g h \cos(y) \\ &\quad - K_s \zeta_2 \sin(y) + K_s \ddot{y} \zeta_3 + \zeta_1^2 \dot{y} K_s + \zeta_1^2 y^{(3)} J l \\ &\quad + K_s R m J h \ddot{y} - \cos(y) \zeta_2 J h \ddot{y}). \end{aligned} \quad (28)$$

4.2. Closed loop synchronization by motion planning

To track the reference trajectory with added disturbances or uncertainty, we define a function [34] $f_d \in Ty$ given a reference trajectory $t \mapsto y_L^*(t)$ of (y, f) . We find a feedback law $y_F \mapsto u(y_F)$ and the error $y_L^* - y_F$ denoted by e_s such that

$$\dot{e}_s(t) = f_d(e_s(t) + y_L^*(t), u(e_s(t) + y_L^*(t))) - f(y_L^*(t), u^*(t)) \quad (29)$$

is asymptotically stable for all disturbances.

f_d represents the set of variables $(x$ and $u)$ of the actual follower robot that is set to converge to their reference f . From Eq. (11), the control can be set as:

$$v_i = v_i^* - \sum_{j=0}^4 K_{i,j} e_{si}^{(j)} \quad i = 1, 2, 3, 4. \quad (30)$$

The gains $K_{i,j}$ are chosen such that the roots of the polynomial of Eq. (12) have negative real part. Therefore if $d(t)$ converges to zero as $t \rightarrow \infty$, then the error exponentially converges to 0.

$$e_i^{(4)} = - \sum_{j=0}^3 K_{i,j} e_{si}^{(j)} + d_i \quad i = 1, 2, 3, 4. \quad (31)$$

The output of the follower robot y_F and all its derivatives up to the 4th order converges to their reference y_L up to the 4th order. Based on the equivalence of the variables $x(t)$ and $u(t)$ as in Eq. (27), it may be concluded that the follower robot variables in the function f_d will exponentially converge to their reference in the presence of perturbations.

If the leader robot were to move in a trajectory from a point $y(t_1) = 0$ to another point $y(t_2) = 0.06$, without any obstacles, then we have 10 constraints, 5 at the initial time: $y(t_1), \dot{y}(t_1), \ddot{y}(t_1), y^{(3)}(t_1), y^{(4)}(t_1)$ and 5 and at the final instant: $y(t_2), \dot{y}(t_2), \ddot{y}(t_2), y^{(3)}(t_2), y^{(4)}(t_2)$. The reference trajectory for the output tip position y_L^* is hereby given by:

$$\begin{aligned} y^*(t) &= y^*(t_1) + (y^*(t_2) - y^*(t_1)) \left(\frac{t - t_1}{t_2 - t_1} \right)^5 \\ &\quad \times \sum_{j=0}^4 \alpha_j \left(\frac{t - t_1}{t_2 - t_1} \right)^j \end{aligned} \quad (32)$$

where the coefficients are calculated by linear interpolation as: $a_0 = 7.56, a_1 = -25.2, a_2 = 32.4, a_3 = -18.9$ and $a_4 = 4$.

Hence the goal of maneuvering the robot between two points is reduced to a finding the solution of the flat output as functions of time.

For the controller to be bounded, we ensure that the bounds of the time duration T are strictly followed.

Defining $\tau = \frac{t-t_1}{t_2-t_1} = \frac{t-t_1}{T}$, we obtain

$$\begin{aligned} \dot{y}(t) &= \frac{1}{T} \frac{dy}{d\tau}(\tau(t)) \\ \ddot{y}(t) &= \frac{1}{T^2} \frac{d^2y}{d\tau^2}(\tau(t)) \\ &\vdots \\ &\vdots \\ y^{(k)}(t) &= \frac{1}{T^k} \frac{d^k y}{d\tau^k}(\tau(t)) \end{aligned}$$

and

$$\max_{t \in [t_i, t_f]} \|y^{(k)}\| = \frac{1}{T^k} \max_{\tau \in [0,1]} \left\| \frac{d^k y}{d\tau^k}(\tau) \right\|, \quad \forall k \geq 1$$

which guarantees that the derivatives $\|\dot{y}\|, \dots, \|y^{(k)}\|$ remain bounded [34].

5. Simulations and results

To show the effectiveness of the synchronization control, first we demonstrate that if the robot models are known completely without any disturbances, we can steer and coordinate a common trajectory for the multiple robots in open loop. Fig. 4 shows the output of the robot using a control input from the leader robot. It is seen here that the trajectory target is achieved in open loop just

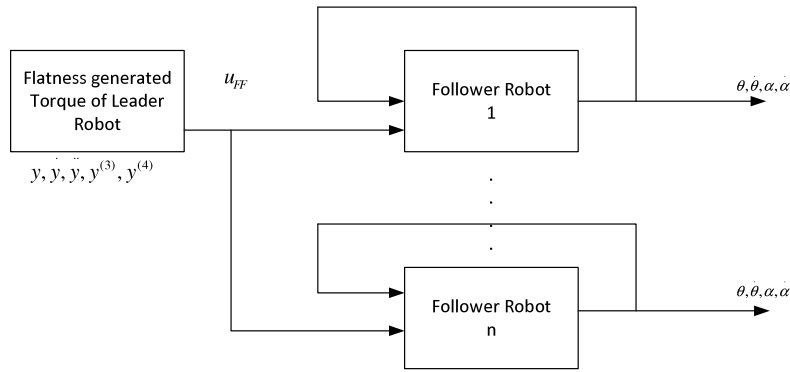

Fig. 3. Open loop synchronization model.

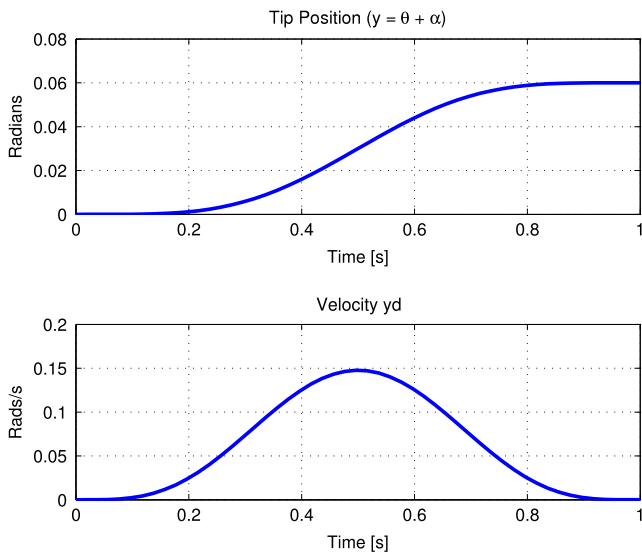

Fig. 4. Tip position and velocity of follower robot in open loop using Leader control input (case 1).

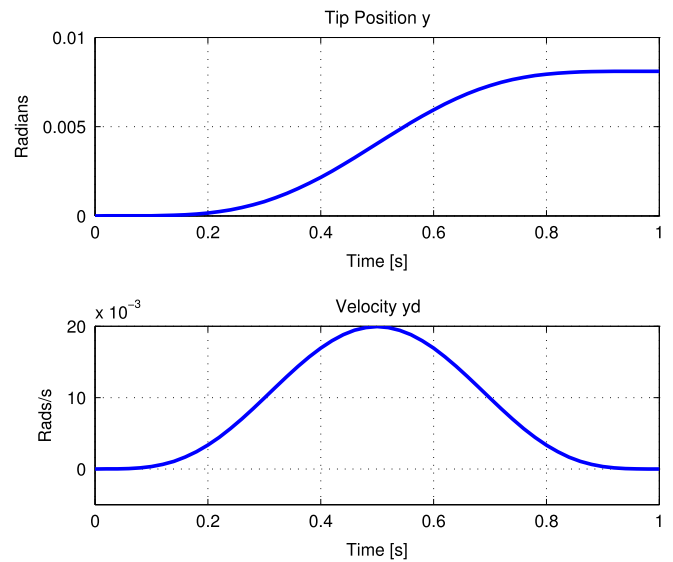

Fig. 5. Tip position and velocity of follower robot in open loop using Leader control input (case 2).

by using the control input of Eq. (28). For the case where α is not measured, we see the position and velocity outputs not attaining their final positions of 0.06 rads and 0.15 rads/s respectively as shown in Fig. 5. This is so due to the underactuation which is not compensated for in open loop.

Figs. 6–9 show closed loop simulations for the two cases. It is seen that synchronizing the trajectories between the leader and follower robots were done using the flat controllers designed in Section 3. The follower robot was able to follow closely the leader robot trajectories for the fully measured position $y = \theta + \alpha$. It is seen here that since link deflections are compensated for in the synchronization control, the results of the tracking are as required. The results for the underactuated robot case are not as satisfactory as the first case. However, the results show a very close tracking performance. The controller was also tested using an arbitrary sine wave as shown in Fig. 6. The effect of perturbations was checked and it is seen that the controller was able to reject and stabilize the trajectories as shown in Figs. 9 and 10.

6. Conclusion

The coordination control of two flexible joint robot manipulators using flat outputs has been implemented in this paper by means of simulations. The differential flatness technique of trajectory generation enables easy estimation of synchronization parameters and trivializes stabilization of these trajectories around pre-defined points. Coordination was conducted for two similar robots

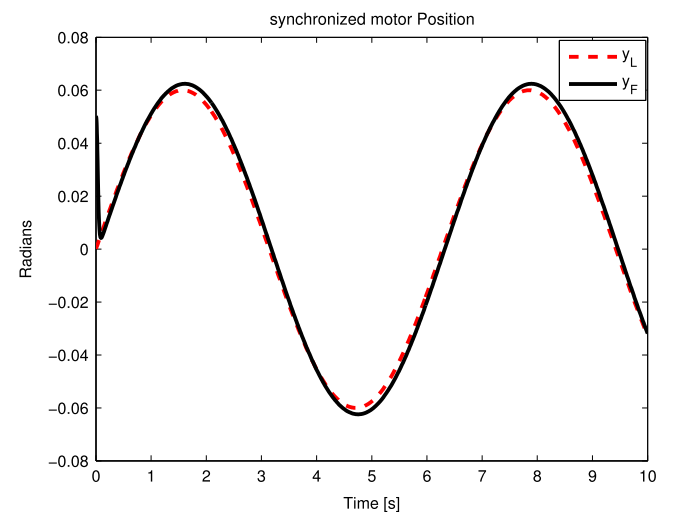

Fig. 6. Tip position of follower and leader robots in closed loop for sine wave reference.

with fully measured tip position and partially measured position as is the case in underactuated robots. Based on the results obtained, the use of flat outputs for coordination of robots has great potential

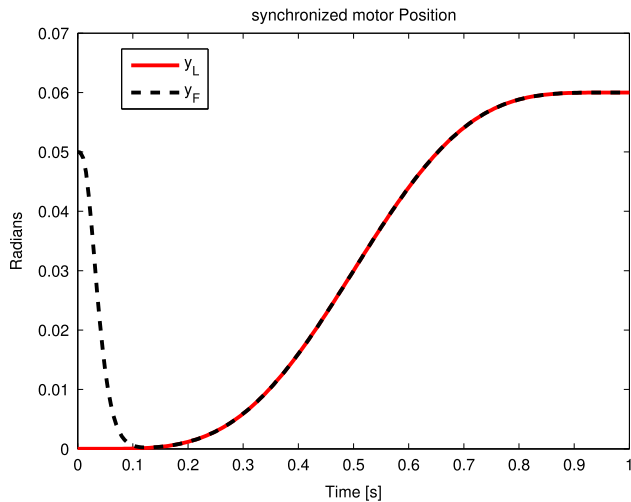

Fig. 7. Tip position of follower and leader robots in closed loop for flat output reference (case 1).

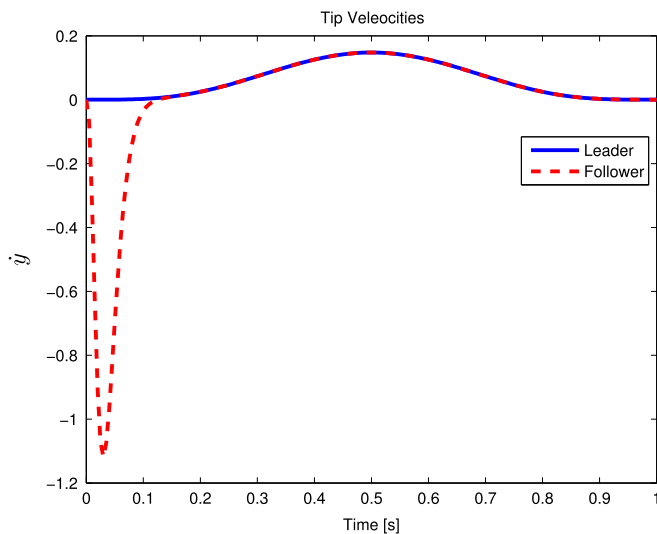

Fig. 8. Velocity of follower and leader robots in closed loop for flat output reference (case 1).

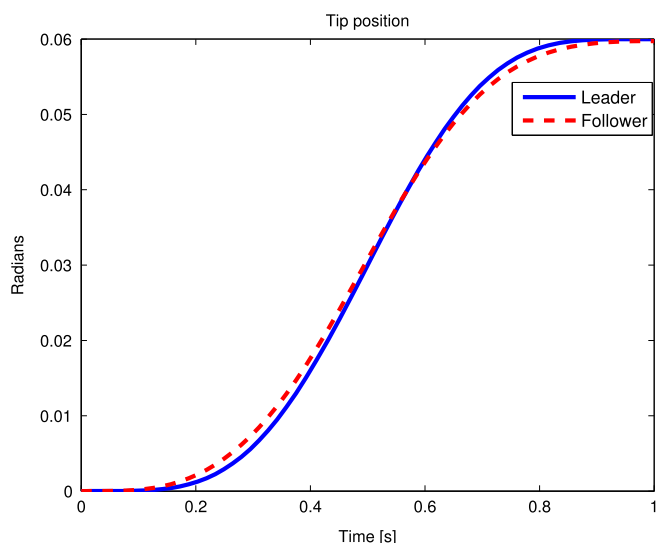

Fig. 9. Tip position of follower and leader robots in closed loop for flat output reference (case 2).

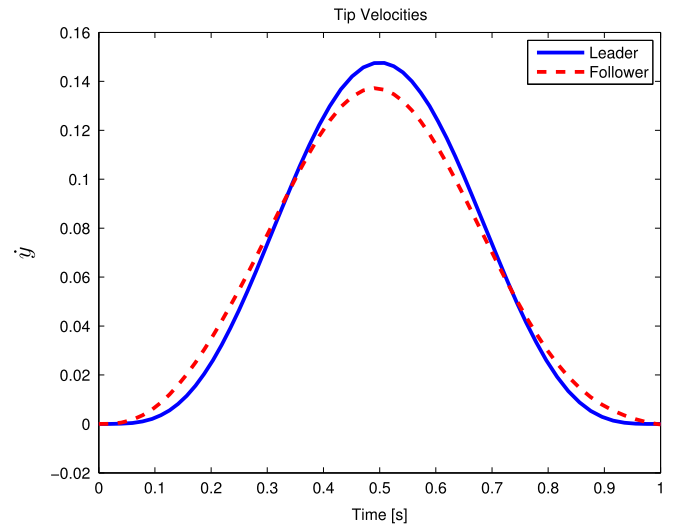

Fig. 10. Velocity of follower and leader robots in closed loop for flat output reference (case 2).

especially where a common trajectory is required to be followed by the robot formations.

References

- [1] S. Yesiloglu, H. Temeltas, General underactuated cooperating manipulators in space manipulation, in: *Recent Advances in Space Technologies, 2005. RAST 2005. Proceedings of 2nd International Conference on, IEEE, 2005*, pp. 293–297.
- [2] Wang Jianan, Ming Xin, Distributed optimal cooperative tracking control of multiple autonomous robots, *Robot. Auton. Syst.* 60 (4) (2012) 572–583.
- [3] T. Endo, F. Matsuno, H. Kawasaki, Simple boundary cooperative control of two one-link flexible arms for grasping, *IEEE Trans. Automat. Control* 54 (10) (2009) 2470–2476.
- [4] M. Bergerman, Y. Xu, Y.-H. Liu, Control of cooperative underactuated manipulators: a robustness comparison study, in: *1st Workshop on Robotics and Mechatronics, Hong Kong. Citeseer, 1998*, pp. 279–286.
- [5] Z. Jing, B. Shi-Xian, The study of coordinated manipulation of two redundant robots with elastic joints, *Mech. Mach. Theory* 35 (7) (2000) 895–909.
- [6] V. Sujan, M. Meggiolaro, Model predictive disturbance rejection during cooperative mobile robot assembly tasks, *J. Braz. Soc. Mech. Sci. Eng.* 26 (3) (2004) 260–268.
- [7] J. Gudi Ño-Lau, M.A. Arteaga, Dynamic model, control and simulation of cooperative robots: A case study, *Mob. Robots Moving Intell.* (2006) 241–270.
- [8] A. Bicchi, D. Prattichizzo, Manipulability of cooperating robots with unactuated joints and closed-chain mechanisms, *IEEE Trans. Robot. Autom.* 16 (4) (2000) 336–345.
- [9] Rahimi Reihane, Farzaneh Abdollahi, Karo Naqshi, Time-varying formation control of a collaborative heterogeneous multi agent system, *Robot. Auton. Syst.* 62 (12) (2014) 1799–1805.
- [10] S. Ahmad, Control of cooperative multiple flexible joint robots, *IEEE Trans. Syst. Man Cybern.* 23 (3) (1993) 833–839.
- [11] R. Kristiansen, P.J. Nicklasson, J.T. Gravdahl, Spacecraft coordination control in 6dof: Integrator backstepping vs passivity-based control, *Automatica* 44 (11) (2008) 2896–2901.
- [12] J. Wang, Z. Sun, 6-dof robust adaptive terminal sliding mode control for spacecraft formation flying, *Acta Astronaut.* 73 (2012) 76–87.
- [13] Q. Hu, J. Zhang, Relative position finite-time coordinated tracking control of spacecraft formation without velocity measurements, *ISA transactions*, 2014.
- [14] C. Tan, L. Si, X. Zhou, Z. Wang, K. Wang, A cooperative control method for fully mechanized mining machines based on fuzzy logic theory and neural networks, *Adv. Mech. Eng.* (2014).
- [15] A. Wiktor, D. Scobee, S. Messenger, C. Clark, Decentralized and complete multi-robot motion planning in confined spaces, in: *Intelligent Robots and Systems, IROS 2014, 2014 IEEE/RSJ International Conference on, IEEE, 2014*, pp. 1168–1175.
- [16] W. Rone, P. Ben-Tzvi, Mapping, localization and motion planning in mobile multi-robotic systems, *Robotica* 31 (01) (2013) 1–23.
- [17] H.-B. Kuntze, C. Frey, T. Emter, J. Peterit, I. Tchouchenkov, T. Mueller, R. Worst, K. Pfeiffer, M. Walter, S. Rademacher, et al. Situation responsive networking of mobile robots for disaster management, in: *ISR/Robotik 2014; 41st International Symposium on Robotics; Proceedings of. VDE, 2014*, pp. 1–8.

- [18] F.L. Lewis, H. Yu, K. Osuka, X. Chen, Cooperative control for multi-agent systems in microgrid distributed generation, in: *Advanced Mechatronic Systems, ICAMechS, 2014 International Conference on, IEEE, 2014*, pp. 1–5.
- [19] B. Cao, G.I. Dodds, G.W. Irwin, A practical approach to near time-optimal inspection-task-sequence planning for two cooperative industrial robot arms, *Int. J. Robot. Res.* 17 (8) (1998) 858–867.
- [20] C. Deng, S. Wang, Z. Huang, Z. Tan, J. Liu, Unmanned aerial vehicles for power line inspection: A cooperative way in platforms and communications, *J. Commun.* 9 (9) (2014).
- [21] D. Zhao, S. Li, Q. Zhu, Adaptive synchronised tracking control for multiple robotic manipulators with uncertain kinematics and dynamics, *Int. J. Syst. Sci.* (2014) 1–14. no. ahead of print.
- [22] D. Zhao, Q. Zhu, N. Li, S. Li, Synchronized control with neuro-agents for leader-follower based multiple robotic manipulators, *Neurocomputing* 124 (2014) 149–161.
- [23] S.S. Chiddarwar, N.R. Babu, Multi-agent system for off-line coordinated motion planning of multiple industrial robots, *Int. J. Adv. Robot. Syst.* 8 (1) (2011) 102–112.
- [24] S.-J. Chung, J.-J. Slotine, Cooperative robot control and concurrent synchronization of lagrangian systems, *IEEE Trans. Robot.* 25 (3) (2009) 686–700.
- [25] T. Lee, H.-S. Ahn, Consensus of nonlinear system using feedback linearization, in: *Mechatronics and Embedded Systems and Applications (MESA), 2010 IEEE/ASME International Conference on, IEEE, 2010*, pp. 26–31.
- [26] A. Bidram, F.L. Lewis, A. Davoudi, Synchronization of nonlinear heterogeneous cooperative systems using input-output feedback linearization, *Automatica* 50 (10) (2014) 2578–2585.
- [27] Fliess Michel, Analyse non standard du bruit, *C. R. Math.* 342 (10) (2006) 797–802.
- [28] M. Fliess, C. Join, H. Sira-Ramirez, Non-linear estimation is easy, *Int. J. Model. Ident. Control* 4 (1) (2008) 12–27.
- [29] Menhour Lghani, et al., Coupled nonlinear vehicle control: Flatness-based setting with algebraic estimation techniques, *Control Eng. Pract.* 22 (2014) 135–146.
- [30] Levine Jean, On the synchronization of a pair of independent windshield wipers, *IEEE Trans. Control Syst. Technol.* 12 (5) (2004) 787–795.
- [31] E. Markus, J. Agee, A. Jimoh, N. Tlale, Nonlinear control of a single-link flexible joint manipulator using differential flatness, in: *Robotics and Mechatronics Conference (ROBMECH), IEEE, 2012*.
- [32] M. Fliess, J. Lvine, P. Martin, F. Ollivier, P. Rouchon, Controlling nonlinear systems by flatness, in: *Systems and Control in the Twenty-first Century, 1997*, pp. 137–154.
- [33] M. Fliess, J. Lvine, P. Martin, P. Rouchon, A lie-backlund approach to equivalence and flatness of nonlinear systems, *IEEE Trans. Automat. Control* 44 (5) (1999) 922–937.
- [34] J. Levine, *Analysis and Control of Nonlinear Systems: A Flatness-based Approach*, Springer, 2009.
- [35] H. Sira-Ramirez, S.K. Agrawal, *Differentially Flat Systems*, vol. 17, CRC, 2004.
- [36] A. Rodriguez-Angeles, H. Nijmeijer, Mutual synchronization of robots via estimated state feedback: a cooperative approach, *IEEE Trans. Control Syst. Technol.* 12 (4) (2004) 542–554.
- [37] [33] M. Fliess, Analyse non standard du bruit, *C. R. Math.* 342 (10) (2006) 797–802.
- [38] [34] M. Fliess, H. Sira-Ramirez, et al. Control via state estimations of some nonlinear systems, in: *IFAC Symposium on Nonlinear Control Systems (NOLCOS 2004), 2004*.



Elisha D. Markus received his B.Eng. and M.Eng. degrees from Abubakar Tafawa Balewa University, Nigeria in 1997 and 2001 respectively. He worked in the Telecommunications industry for about 10 years before joining the university as a lecturer. He is currently a doctoral student at Tshwane University of Technology in South Africa and also a lecturer at Central University of Technology in the Free State South Africa. His research interests include nonlinear control, robotics, Power systems, Differential Flatness, Telecommunications and artificial intelligence.



Prof. Hamam Yskander is a Professor at FSATI Department of Electrical Engineering and Department of Mechanical Engineering Faculty of ICT Université de Versailles – St Quentin en Yvelines, France Université de Paris Est Creteil, France ESIEE. His research interests include: Control, Image Processing, Machine Intelligence (CIPMI), Modeling & Simulation applied to the enabled environment, Enabling Devices (Intelligent wheelchairs, human-machine interfaces, mechatronic devices), Tele-vigilance (Sensors & Sensor signal processing in an enabled environment), e-Health & Enabled Environment Planning, Modeling and optimization in wireless communication networks.



Prof. John T. Agee was born in 1964. He obtained a B.Eng. (Hons), 2nd Class Upper division in Electrical and Electronics Engineering in 1989, an M.Eng. (Electronics) degree in 1992 and a Ph.D. in Control Systems Engineering in 2001; all from the Abubakar Tafawa Balewa University, Bauchi, Nigeria. He started his academic career in 1990 as a Graduate Assistant. He became a Senior Lecturer in 2001. His research interests include nonlinear control with applications in power systems. He is also researching in artificial intelligence and its application in smart drive control.



Prof. Adisa A. Jimoh received B.Eng. degree in 1977 and M.Eng. degree in 1980, both from Ahmadu Bello University (ABU) Zaria, Nigeria and a Ph.D. degree from McMaster University, Hamilton, Canada in 1986. He was with Ahmadu Bello University up till 1992, when he moved to the Research & Development unit of the National Electric Power Authority (NEPA) Nigeria. Adisa was with NEPA up till 1996 when he relocated to the University of Durban-Westville, Durban, South Africa where he taught courses and carried out research in high performance energy efficient electric machines and power systems, and power electronics. In 2001 he joined Tshwane University of Technology, Pretoria, where, as a full professor, he leads and coordinates the research and doctorate programs of the Graduate School of Electrical and Electronic Engineering. He is a registered engineer in South Africa. His research interests are in the field of Electric Machines, Drives and Power Electronics application in Power Systems.